



WR-1.5 & WR-1.5e Remote Control

The WR-1.5 combines the level control capability of the WR-1 and the preset recall capability of the WR-2. A single potentiometer and four position rotary switch offer independent control of level and preset recall, and can be wired to the same or different hosting devices. *The WR-1.5e is functionally the same as the WR-1.5 but is designed to mount in a UK electrical wall box (see illustration on page 2).*

Compatible Ashly products include:

- ne24.24M
- NE 800, 1600, and 2400 two-channel power amplifiers *
- NE 4250 and 8250 multi-channel power amplifiers (with DSP)
- NE 8800, 4800, and 4400 DSP processors (using logic I/O)
- PEMA™ power amplifiers
- nXe and nXp power amplifiers

** Remote level control only, no preset recall*

Power and mounting - The WR-1.5 is a passive controller and thus requires no power other than the +5VDC provided by the hosting unit for level control. The WR-1.5 mounts to a standard US electrical wall box. The *WR-1.5e* mounts to a standard UK electrical wall box. Ashly recommends earth grounding the WR-1.5(e) frame at the point of installation to avoid static discharge into the host device.

Remote Level Control - The WR-1.5 connects to the host unit's remote level control pins as shown below. In some devices, the CV input may need to be assigned its function in Protea^{nc} Software using a remote level control function, found in or plugged into the DSP section.

Preset Recall - The five preset recall wires connect to the host unit's preset recall or logic I/O connector, if available*. The four switch positions can correspond directly to the first four numbered presets stored in the host unit's internal memory, or may be assigned a logic I/O function in some units.

Labels - On the WR-1.5 only, windows are provided for level and preset labels. Units ship from the factory with "Level" and "1-4" labels installed, but they can be easily replaced (see below) with a user-editable label document available on the Ashly website under Downloads>Application Notes for the WR-1.5. *The WR-1.5e has a writable surface for labeling controls, label inserts are unavailable.*

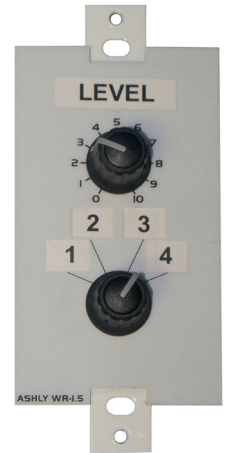

Wiring a WR-1.5 to the Host Unit

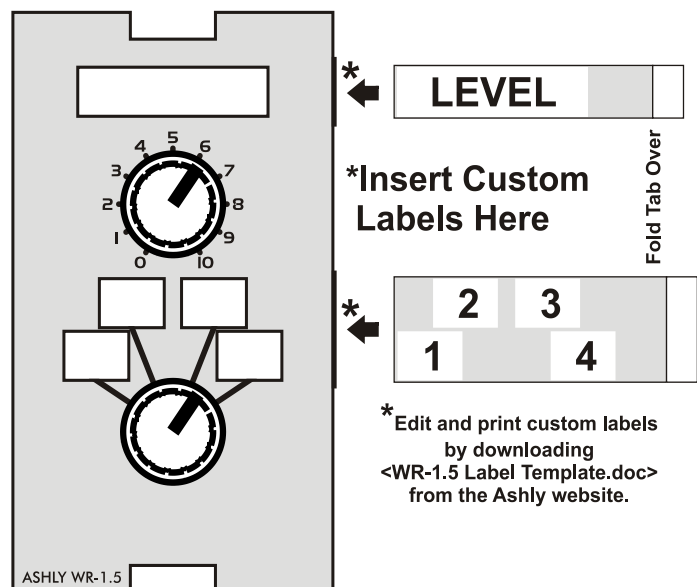
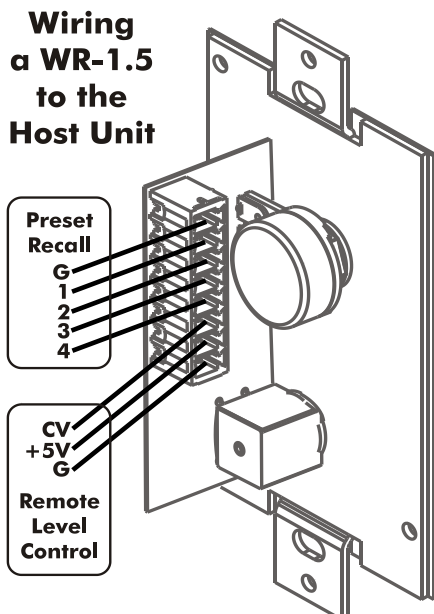

WR-1.5e UK Wall-Box Version:

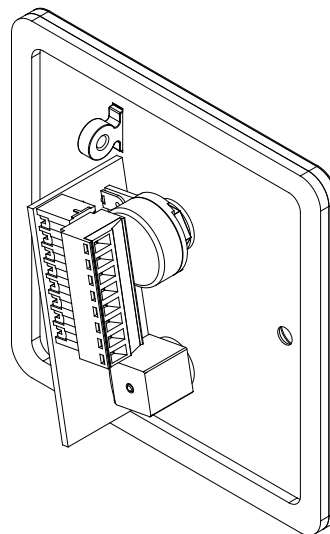
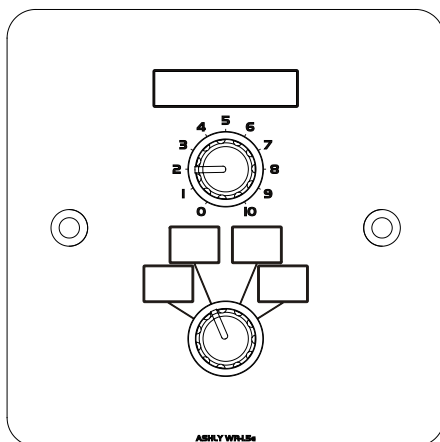

Ashly Audio Inc. LIMITED WARRANTY (USA ONLY)

(Other countries please contact your respective distributor or dealer.)

For units purchased in the USA, warranty service for this unit shall be provided by ASHLY AUDIO, INC. in accordance with the following warranty statement.

ASHLY AUDIO, INC. warrants to the owner of this product that it will be free from defects in workmanship and materials for a period of FIVE years from the original-date-of-purchase. ASHLY AUDIO INC. will without charge, repair or replace at its discretion, any defective product or component parts upon prepaid delivery of the product to the ASHLY AUDIO, INC. factory service department, accompanied with a proof of original-date-of-purchase in the form of a valid sales receipt. This warranty gives you specific legal rights, and you may also have other rights, which vary from state to state.

EXCLUSIONS: This warranty does not apply in the event of misuse, neglect, or as a result of unauthorized alterations or repairs made to the product. This warranty is void if the serial number is altered, defaced, or removed. ASHLY AUDIO, INC. reserves the right to make changes in design, or make additions to, or improvements upon, this product without any obligation to install the same on products previously manufactured.

Any implied warranties, which may arise under the operation of state law, shall be effective only for FIVE years from the original-date-of-purchase of the product. ASHLY AUDIO, INC. shall be obligated to only correct defects in the product itself. ASHLY AUDIO, INC. is not liable for any damage or injury, which may result from, or be incidental to, or a consequence of, such defects. Some states do not allow limitations on how long an implied warranty lasts, or the exclusion, or limitation of incidental or consequential damages, so the above limitations or exclusions may not apply to you.

OBTAINING WARRANTY SERVICE:

For warranty service in the United States, please follow this procedure:

1) Return the product to ASHLY AUDIO, INC. freight prepaid, with a written statement describing the defect and application that the product is used in. ASHLY AUDIO, INC. will examine the product and perform any necessary service, including replacement of defective parts, at no further cost to you.

2) Ship your product to:
ASHLY AUDIO, INC.
Attention: Service Department
847 Holt Road
Webster, NY 14580-9103

ASHLY AUDIO INC. 847 Holt Road Webster, NY 14580-9103, USA
Phone: (585) 872-0010 Fax: (585) 872-0739
Toll Free (800) 828-6308 www.ashly.com

©2016 by Ashly Audio Corporation. All rights reserved worldwide.
Ashly Audio is a division of Jam Industries, Ltd.

All features, specifications, and graphical representations are subject to change or improvement without notice.

