



FX SERIES

FX-750.4

FX-750.2

FX-500.4

FX-500.2

FX-125.4

FX-125.2

FX-60.4

FX-60.2

4- and 2-channel

Power Amplifiers

Note: This manual reflects operations included in firmware v1.4. If your amplifier firmware is an older version, some of these features will not be available. You may update the firmware for your FX amplifier by downloading the latest firmware [here](#).

Operating Manual



Technical and Safety Notices

Please read the following important technical, safety and environmental notices before installing and using your amplifier.

Technical Notices

All reasonable design and engineering steps have been taken to ensure that these amplifiers always perform satisfactorily in their intended application and environment and will provide appropriate levels of support to ensure that all reasonable customer needs and expectations are met. Such support however is contingent on the following provisions.

These amplifiers are Class-I products and should be installed with a mains cable including the required earth connection to comply with the Safety Class-I.

These amplifiers should always be installed by competent and qualified personnel. Amplifier damage or failure caused by installation or operational errors may invalidate support, warranty or guarantees of performance.

These amplifiers are not suitable for use in locations where they may be accessible to minors.

These amplifiers are intended to be used specifically for the amplification of audio signals and for connection to moving-coil loudspeaker systems. Use of these amplifiers for amplification of signals outside the audio band (20Hz to 20kHz) or to drive transducers other than moving-coil loudspeakers may invalidate support, warranty or guarantees of performance.

These amplifiers should only be used within professionally installed and configured audio systems comprising input and output ancillary equipments that is known to be of an appropriate level of performance and in good operating condition. Any damage to, or unsatisfactory performance from, these amplifiers caused by inadequate or failed input or output ancillaries may invalidate support, warranty or guarantees of performance.

These amplifiers are intended to be installed and operated indoor in a controlled environment (pollution degree, PD2) within an ambient temperature range of 0°C to 40°C. These amplifiers are not intended for use above 2000 meters above sea level. Amplifiers installation

or operated in environments outside these limits may invalidate support, warranty or guarantees of performance.

Specific warranty terms are the responsibility of the amplifier reseller.

Safety and Environmental Notices

Note: The intent of the lightning flash with arrowhead symbol in a triangle is to alert the user to the presence of uninsulated “dangerous” voltage within the product’s enclosure that may be of sufficient magnitude to constitute a risk of electric shock to humans.

Note: The intent of the exclamation point within an equilateral triangle is to alert the user to the presence of important safety, and operating and maintenance instructions in this manual.



WARNING! TO PREVENT FIRE OR ELECTRIC SHOCK, DO NOT EXPOSE THIS EQUIPMENT TO RAIN OR MOISTURE.

Ambient Temperature Note:
If this equipment is operated in a confined or multiple rack installation, the internal ambient operating temperature may exceed the external ambient temperature. It is important to ensure in these circumstances that the published maximum operating temperature for the equipment is not exceeded.

Reduced Air Flow: Ensure that rack or other closed installation does not restrict the cooling airflow required for safe and reliable operation of the equipment.



Important Safety Instructions and Environmental Statement

Read these instructions.

Keep these instructions.

Heed all warnings.

Follow all instructions.

Do not use this apparatus near water.

Do not submerge the equipment in water or liquids.

Do not use any aerosol spray, cleaner, disinfectant or fumigant on, near or into the equipment.

Clean only with a dry cloth.

Do not block any ventilation opening. Install in accordance with the manufacturer's instructions.

Do not install near any heat sources such as radiators, heat registers, stoves, or other apparatus (including amplifiers) that produce heat.

To reduce the risk of electrical shock, the power cord shall be connected to a mains socket outlet with a protective earthing connection.

Do not defeat the safety purpose of the polarized or grounding type plug. A polarized plug has two blades with one wider than the other. A grounding type plug has two blades and a third grounding prong. The wide blade or the third

prong are provided for your safety. If the provided plug does not fit into your outlet, consult an electrician for replacement of the obsolete outlet.

Protect the power cord from being walked on or pinched particularly at plugs, convenience receptacles, and the point where they exit from the apparatus.

Do not unplug the unit by pulling on the cord, use the plug.

Only use attachments/accessories specified by the manufacturer.

Unplug this apparatus during lightning storms or when unused for long periods of time.

Refer all servicing to qualified service personnel. Servicing is required when the apparatus has been damaged in any way, such as power supply cord or plug is damaged, liquid has been spilled or objects have fallen into the apparatus, the apparatus has been exposed to rain or moisture, does not operate normally, or has been dropped.

The appliance coupler, or the AC Mains plug, is the AC mains disconnect device and shall remain readily accessible after installation.

Adhere to all applicable, local codes.

Consult a licensed, professional engineer when any doubt or questions arise regarding a physical equipment installation.

Environmental Statement

This product complies with international directives, including but not limited to the Restriction of Hazardous Substances (RoHS) in electrical and electronic equipment, the Registration, Evaluation, Authorization and restriction of Chemicals (REACH) and the disposal of Waste Electrical and Electronic Equipment (WEEE). Consult your local waste disposal authority for guidance on how properly to recycle or dispose of this product.



FCC Compliance

This device complies with part 15 of the FCC Rules. Operation is subject to the following two conditions:

This device may not cause harmful interference

This device must accept any interference received, including interference that may cause undesired operation

Note: This equipment has been tested and found to comply with the limits for a Class B digital device, pursuant to part 15 of the FCC Rules. These limits are designed to provide reasonable protection against harmful interference in both a commercial and residential installation. This equipment generates, uses and can radiate radio frequency energy and, if not installed and used in accordance with the instructions, may cause harmful interference to radio communications. However, there is no guarantee that interference will not occur in a particular installation. If this equipment does cause harmful interference to radio or television reception, which can be determined by turning the equipment off and on, the user is encouraged to try to correct the interference by one or more of the following measures:

Reorient or relocate the receiving antenna.

Increase the separation between the equipment and receiver.

Connect the equipment into an outlet on a circuit different from that to which the receiver is connected.

Consult the dealer or an experienced radio/TV technician for help.

Unpacking

As a part of our system of quality control, every Ashly product is carefully inspected before leaving the factory to ensure flawless appearance.

After unpacking, please inspect for any physical damage. Save the shipping carton and all packing materials, as they were carefully designed to reduce to a minimum the possibility of transportation damage should the unit again require packing and shipping. In the event that damage has occurred, immediately notify your dealer so that a written claim to cover the damages can be initiated.

The right to any claim against a public carrier can be forfeited if the carrier is not notified promptly and if the shipping carton and packing materials are not available for inspection by the carrier. Save all packing materials until the claim has been settled.

About Ashly

Ashly Audio was founded in 1974 by a group of recording engineers, concert sound professionals, and electronics designers. The first products were elaborate custom consoles for friends and associates, but business quickly spread to new clients and the business grew.

The philosophy we established from the very beginning holds true today: to offer only the highest quality audio tools at an affordable cost to the professional user – ensuring reliability and long life. Years later, Ashly remains committed to these principles.

Ashly's exclusive five-year, worry-free warranty remains one of the most generous policies available on any commercial-grade product. The warranty covers every product with the Ashly brand name, and is offered at no extra cost to you.

Please read this entire manual to fully understand the features and capabilities of this product.

1. Introduction and Overview

FX IP connected power amplifiers have been designed to provide configurable, consistent and reliable high performance audio power amplification for residential, commercial and entertainment applications. Please read this manual fully before installing and using an amplifier. If you have any questions regarding amplifier configuration, installation or operation please contact the appropriate customer support portal.

Table of Contents

- 1 - [Amplifier Overview](#)
- 2 - [Carton Contents](#)
- 3 - [Installation](#)
- 4 - [AC Mains and Network Configuration](#)
- 5 - [Configuration Menus](#)
- 6 - [Setup and Signal Routing](#)
- 7 - [GPIO Setup and Connections](#)
- 8 - [Input and Speaker Connections](#)
- 9 - [Operation](#)
- 10 - [Signal Flow and Panel Diagrams](#)
- 11 - [Specifications](#)
- 12 - [Rear Panel Drawings](#)
- 13 - [FXC Remotes](#)
- 14 - [Warranty](#)

**Note: In Lo-Z Bridge mode:*

Two amplifier output channels are combined to create a single, double power output channel. Bridge mode can be engaged via the amplifier Output Mode configuration setup menu described in [Section 6.3](#) of this manual.

1.1a Full-Rack, FX500/750 Models

FX 750.4, FX 750.2, FX 500.4, FX 500.2

The higher powered 2RU FX amplifiers can drive both conventional low impedance loudspeakers (Low-Z mode, 2Ω to 16Ω), and high impedance (Hi-Z, 70V/100V) transformer coupled loudspeakers. Each model provides four analog inputs, stereo S/PDIF digital input & output, and either two or four outputs (Low-Z mode), or one or two output (Hi-Z or Lo-Z Bridge* mode).

Note: 2RU FX amplifiers do not incorporate automatic power sharing technology.

Model & Mode	Channels	Max Rated Output/Ch
FX 750.4		
Lo-Z	Four	750W
*Lo-Z (Bridge)	Two	1500W
Hi-Z (Bridge)	Two	1500W
FX 750.2		
Lo-Z	Two	750W
*Lo-Z (Bridge)	One	1500W
Hi-Z (Bridge)	One	1500W
FX 500.4		
Lo-Z	Four	500W
*Lo-Z (Bridge)	Two	1000W
Hi-Z (Bridge)	Two	1000W
FX 500.2		
Lo-Z	Two	500W
*Lo-Z (Bridge)	One	1000W
Hi-Z (Bridge)	One	1000W

1.1b Half-Rack, FX125/60 Models

FX 125.4, FX 125.2, FX 60.4, FX 60.2

FX half-rack amplifiers can drive conventional low impedance (Low-Z, 4Ω to 16Ω) loudspeakers and high impedance (Hi-Z, 70V/100V) transformer coupled loudspeakers. Each model provides four analog inputs, stereo S/PDIF digital input & output, and either two or four outputs (Low-Z mode), or one or two output (Hi-Z or Lo-Z *Bridge mode).

FX half-rack amplifiers incorporate automatic power sharing technology that enables power to be shared proportionately as required between two outputs when in Low-Z mode.

Model & Mode	Channels	Max Rated Output/Ch
FX 125.4		
Lo-Z	Four	125W
*Lo-Z (Bridge)	Two	250W
Hi-Z	Two	250W
FX 125.2		
Lo-Z	Two	125W
*Lo-Z (Bridge)	One	250W
Hi-Z	One	250W
FX 60.4		
Lo-Z	Four	60W
*Lo-Z (Bridge)	Two	120W
Hi-Z	Two	120W
FX 60.2		
Lo-Z	Two	60W
*Lo-Z (Bridge)	One	120W
Hi-Z	One	120W

1.2 Connections

FX amplifier audio input and output connections are accomplished via Euroblock, RCA Phono, and RCA S/PDIF connectors. A GPIO (General Purpose In/Out) Euroblock connector enables certain amplifier functions to be controlled remotely. FX amplifiers provide both their own WiFi hotspot and RJ45 Ethernet LAN connection for software configuration.

Note: Half-rack FX amplifiers have no mains power switch and are operational as soon as mains power is connected via the IEC 60320 mains socket.

1.3 Network Features

FX amplifiers are TCP/IP network connected devices that require a wireless or wired network connection to access their configuration menus. The configuration menus are accessed via a web page interface served up directly by the amplifier, so there is no application to install. The interface offers access to the main Dashboard, plus Input, Zone, Output, and General Settings.

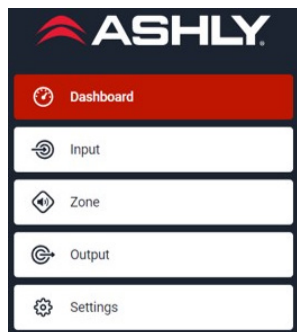

The configuration menus are fully described in [Section 5](#).

1.4 Dimensions

FX amplifier dimensions and ventilation requirements are illustrated in Diagrams 1a, 1b, and 1c. All models are fan-cooled and must be installed such that ventilation apertures are not obstructed. Half-rack models can be fitted for full-rack, under-desk, or wall-mounting by purchasing an optional mounting kit. ([see sec. 3.1](#)).

[Table of Contents](#)

2. Carton Contents

FX amplifiers are shipped in a cardboard carton containing the amplifier unit, a mains cable appropriate for the sales territory, an accessory pack, and a document pack. The full contents is listed below.

- Amplifier unit
- Mains power cable
- Input connector x 2
- GPIO socket connector
- Output connector x 1 or 2
- Adhesive rubber feet x 4
- Document pack

Diagram 1a
FX 2RU Full-Rack two & four channel amplifier dimensions. Shaded area defines ventilation space

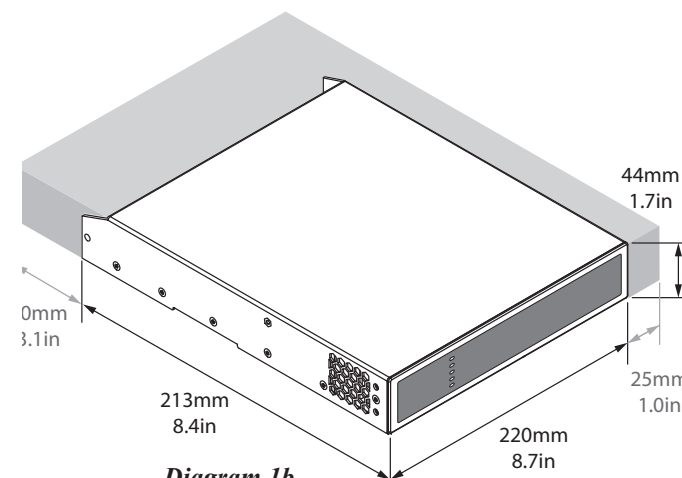
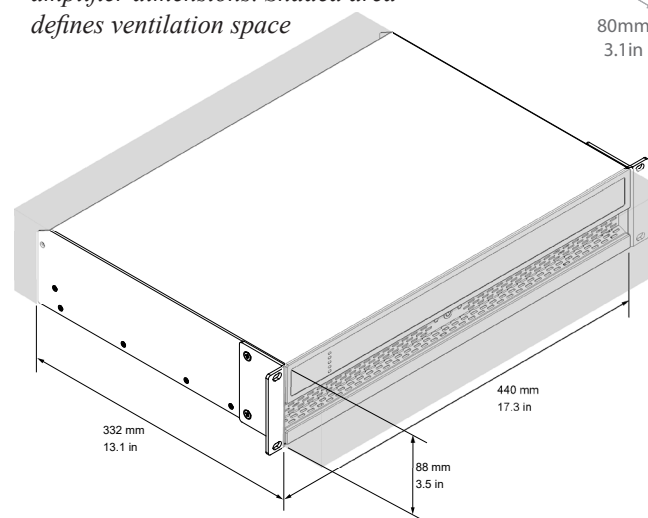

Diagram 1b
FX Half-Rack two channel amplifier dimensions. Shaded area defines ventilation space

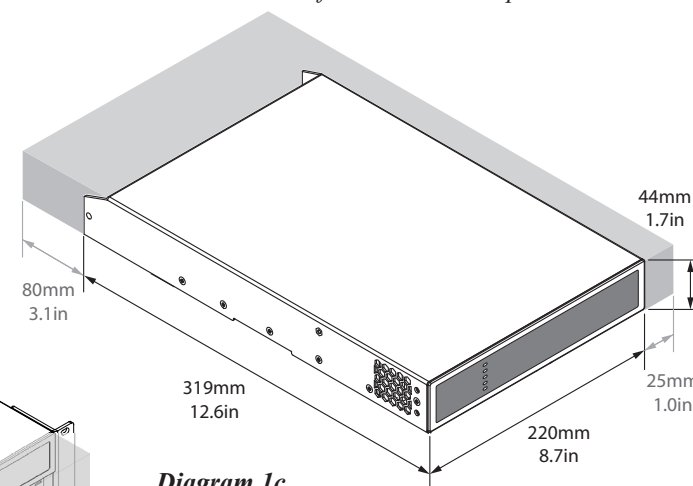

Diagram 1c
FX Half-Rack four channel amplifier dimensions. Shaded area defines ventilation space

3. Installation

Note: For **half-rack** FX models, the rack and desk/wall mounting components described and illustrated in Sections 3.1 and 3.2 are not included with amplifiers, but are available to purchase as accessories. Contact your amplifier re-seller for more information.

3.1 FX Mounting

FX 2RU full-rack amps include rack-mount ears.

Half-rack FX amplifiers are shipped without any rack-mount hardware. A rack-mount kit can be purchased separately and configured as illustrated in *Diagram 3a*.

The installation and equipment rack should be configured to provide appropriate ventilation airflow space around the sides and rear of the amplifier as illustrated in *Diagrams 1a - 1c*. Ventilation airflow space of at least 25 mm (1 in) should be maintained along at least one side of the amplifier at all times. Ventilation apertures are also located on the rear panel of the amplifier and must not be obstructed. It is important to retain at least 80 mm (3.1 in) free space for airflow behind the amplifier rear panel.

In addition to rack mount ears, optional rack mount rear support hardware is available and can be attached to the amplifier. Rear support hardware may be appropriate if the amplifier is to be used in a mobile rack or potentially be subject to significant movement. *Diagram 3b* illustrates the use of rack mount rear support hardware.

Two *half-rack* FX amplifiers can be mechanically joined using the connection plate as illustrated in *Diagram 3c*. The connection plate is included with the FA1.2RM kit. Two small rack ears are included in the same kit for rack mounting two joined FX amplifiers.

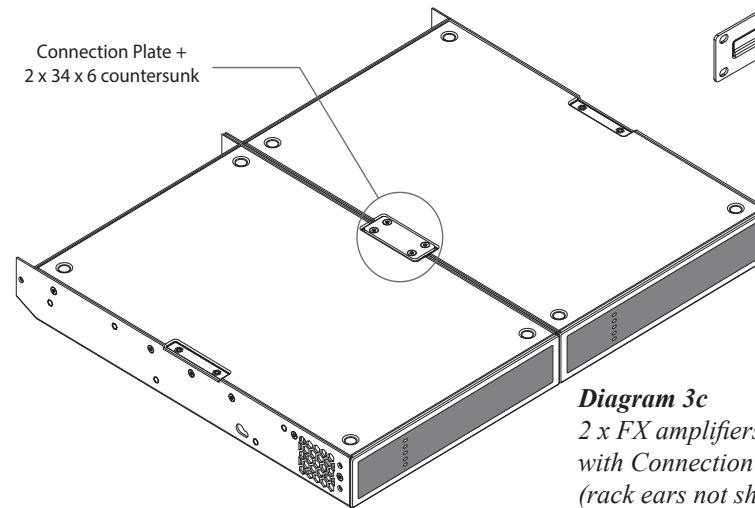
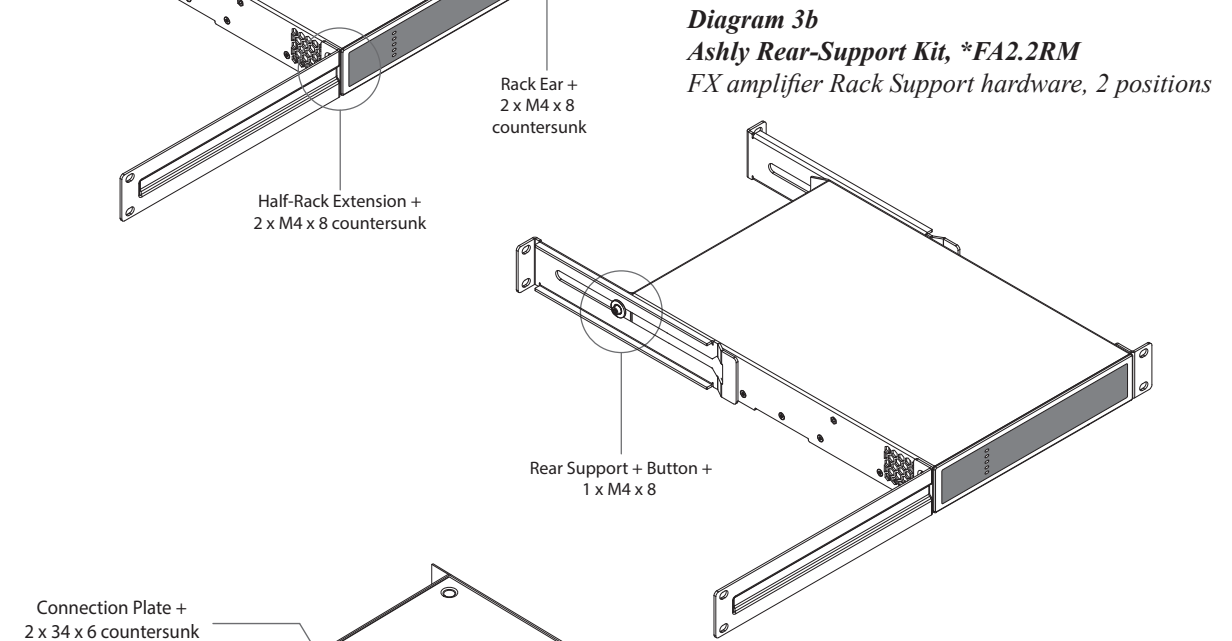
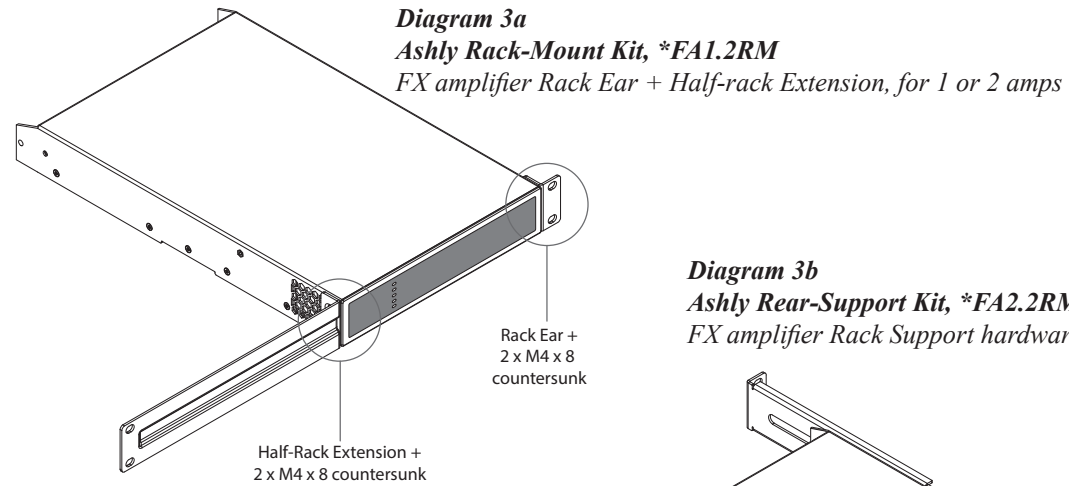

**Half-Rack mounting kits shown are available options and are sold separately.*

3.2 Free-standing

If not installed in an equipment rack, FX amplifiers can be placed free-standing on a flat surface. Adhesive rubber feet are supplied with all FX models for this purpose.

Half-rack FX amplifiers can be attached to the underside of desks or wall mounted using connecting plate hardware. The adhesive rubber feet should also be used in these circumstances to minimize the possibility of vibration between the amplifier and mounting surface. Wall and desk mounting is illustrated in *Diagrams 3d and 3e*.

It is important in any free standing installation that airflow through the amplifier's side panel mounted fans and rear panel ventilation apertures is not compromised by adjacent items. At least 80mm of free space behind the amplifier and 25mm along at least one side (for half-rack units) should be retained at all times.

Note: Full-rack 2RU FX models do not have kits for mounting to a wall or underneath a table, they can only be used free-standing or rack-mounted.

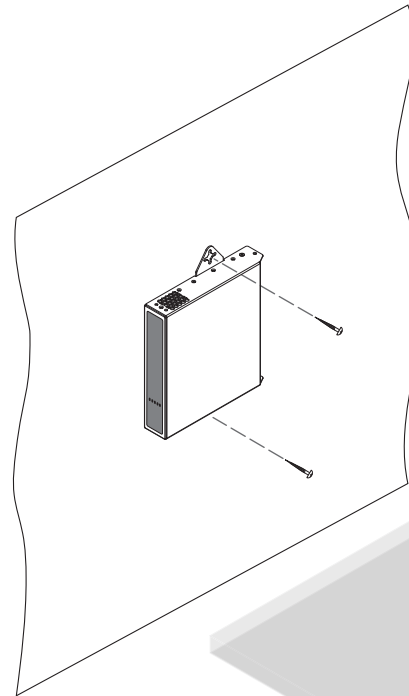
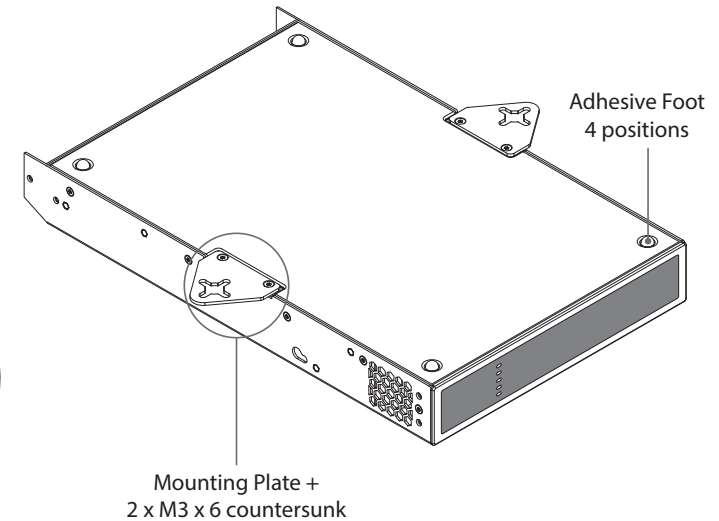

Diagram 3d
Ashly Flush Wall/Table-Mount Kit, *FATWB
 FX amplifier with desk/wall Mounting Plate and adhesive feet.
 2 positions and 4 positions.



**Mounting kits shown are available options and are sold separately.*

Diagram 3e
 FX amplifier
 wall and under-desk mount

4. Configuration

Before making input, output and GPIO connections, an initial FX amplifier configuration should be established. It is particularly important that the output amplifier format is configured appropriately for the speakers that are to be connected.

Configuration requires that FX amplifiers are connected to mains power and network services. These connections are described in the following two sections.

4.1 Mains Power Connection

FX amplifiers incorporate a power factor corrected power supply and can be used with mains input voltage from 100VAC to 240VAC, 50/60Hz. Use the mains cable supplied with the amplifier and connect it to a switched mains supply.

Half-rack FX amplifiers have no mains power switch and are operational as soon as mains power is connected. **Full-rack** FX models have a front panel power switch.

4.2 Network Services

FX amplifiers are configured via a web page interface launched from the amplifier using a TCP/IP Ethernet network connection.

In order to access the web page interface, FX amplifiers must first connect to the browser device, or to the network used by the browser device.

That connection can be made using a wired LAN (use CAT5, CAT5E, or CAT6 cable), the FX amplifier's built-in WiFi Access Point (hotspot), or a local WiFi network (Client Mode).

• Wired LAN (local area network)

A wired LAN connection can be made using Ethernet cable connected directly to a PC, or to a PC through an Ethernet switch/router using CAT5, CAT5E, or CAT6 cable. **Note: the FX amp, PC, and router (if used) must all be on the same subnet.**

Static IP connection: Out of the box, the FX Wired LAN connection uses a Static IP address, meaning the browser must connect using a predetermined fixed IP address. The default IP address for a wired LAN connection on FX amplifiers is **192.168.64.100**. A different Static IP address may be assigned in the FX LAN configuration page.

Ashly recommends using a Static IP address for permanent installations. *Note: If your network devices are connected through a router, then you must log in to the router and set a Static IP reservation for the FX amplifier.*

DHCP connection: The FX amplifier can also be configured in the Settings>LAN menu to instead connect using DHCP, meaning the amplifier receives an IP address automatically assigned by the router. It is not recommended to use DHCP for permanent installations, since the router could potentially change the IP assignment to the FX at any time.

The front panel Network indicator LED will illuminate green to indicate the amplifier has been successfully connected to a wired LAN. To view the current wired LAN IP address on a properly connected unit, go to the FX configuration Dashboard page.

If for some reason you are unable to open the configuration interface using the wired LAN connection, use the WiFi Access Point interface instead, described in the next section. Once connected using WiFi, wired LAN settings can be reviewed and configured.

• WiFi Access Point (hotspot)

Every FX amplifier offers its own dedicated WiFi access point, or "hotspot", for a direct wireless connection to a browser device with no outside network required.

1. With the FX amplifier connected to mains power, wait for the front panel WiFi indicator to illuminate green. This indicates the FX amplifier's Access Point WiFi is available.
2. Using a laptop, tablet, or mobile device, search for available WiFi networks. Connect to the WiFi network called "**Ashly FX (+ model name + serial number)**". The serial number is found on the rear panel. Enter the password, "**password**", which can be renamed later, then connect.
3. Once the WiFi Access Point connection is made, open a web browser and enter the IP address **192.168.4.1**. The amplifier configuration web page interface will open.

Click on the Settings>Wifi menu for further WiFi options including enable/disable WiFi, enable/disable WiFi when connected to LAN, disable WiFi after 5/10/30 minutes, and reset.

• WiFi Client Mode

To connect and configure the FX amplifier using a local WiFi network instead of its dedicated Access Point WiFi, *set the WiFi mode to "Client" in the Settings>WiFi menu. Enter the local WiFi network name (SSID) and password, then click *apply.

***Note: Before changing to WiFi Client Mode, be sure to first establish a successful wired LAN connection. Setting WiFi to Client mode disables access to the FX amplifier's Access Point WiFi. Having a wired LAN connection assures access to the amplifier in case something goes wrong with the local area WiFi connection.**

5. Configuration Menus

Opening a web browser that is network connected to a FX amplifier will initially display five main configuration menu tabs as shown below:

5.1 Dashboard

The Dashboard tab is the 'home' screen from which all other configuration options can be accessed.

Within the Dashboard tab, the following items are available for user control or to indicate status.

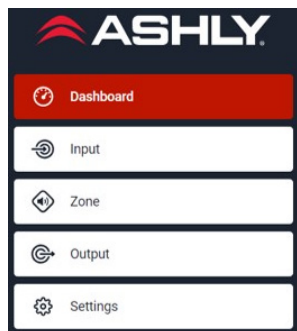

- **Power** - Click on the power button to toggle between ON and Standby. Note: There is no power switch on FX *half-rack* models.
- **Input Status** - Indicates input signal present
- **Output Status** - Indicates output signal present
- **LAN** - Indicates LAN connection & IP address
- **WiFi** - Indicates WiFi connection & IP address
- **Zone Status** - Offers control for Mute/Unmute and Level, and displays an LED meter indicating signal level for available zones (zones A-B for 2-channel models, zones A-D on 4-channel models), and indicates the currently selected input source and output routing (speaker channel) for each zone.

5.2 Input

The input tab is where inputs are initially configured. At the top of the Inputs menu page, select from analog inputs, SPDIF inputs, mixers, or signal generator functions.

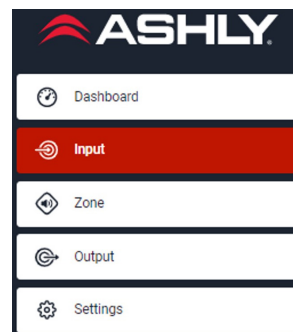

5.2a Input > Analog:

The analog tab (see below) displays all four analog inputs for individual (or stereo pair) configuration and includes the following adjustable parameters for each:

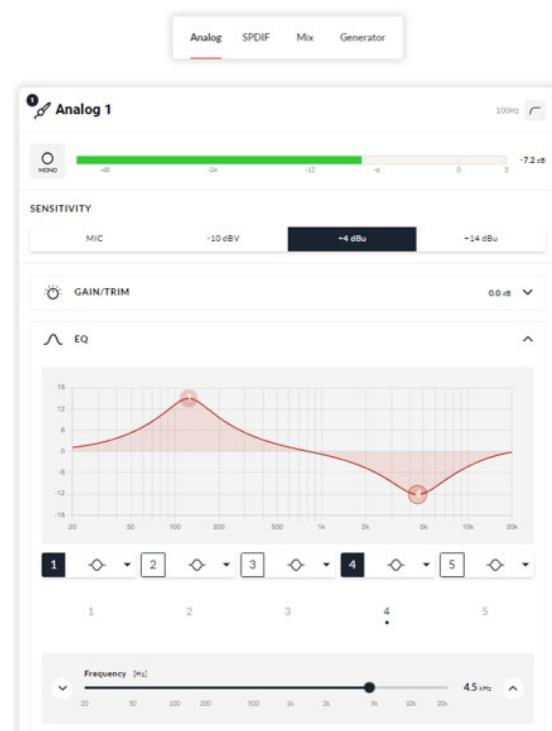

- **Input Name** -Enter up to 16 text characters
- **Mono/Stereo** - Defines an input as either mono or stereo. Stereo input automatically couples the two channels and applies input settings equally to both channels.
- **High Pass Filter** - Fixed at 100Hz, ON/OFF
- **Sensitivity** - Set for the appropriate input signal level. Settings include: +14dBu and +4dBu for balanced pro audio signal (default), -10dBv for HiFi, and Microphone (50mV / -24dBu / -26dBV). *Note: Phantom power for condenser microphones is not provided.*
- **Gain/Trim** - The Input Gain/Trim fader is adjustable ± 15 dB . Gain adjustment is intended to be used for fine level adjustment after input sensitivity selection is made.
- **5-Band EQ** - The EQ graphic display offers selectable Parametric, High Shelf, Low Shelf, HPF, or LPF filter for each band. Filter nodes can be dragged right on the EQ display, or slide faders can be used to adjust filter Frequency, Gain, and Q.

5.2b Input > SPDIF: The input SPDIF tab allows for channel naming, stereo or split mono selection, and input gain control for the digital SPDIF input. Selecting split mono automatically assigns SPDIF input to adjacent input channel pairs.

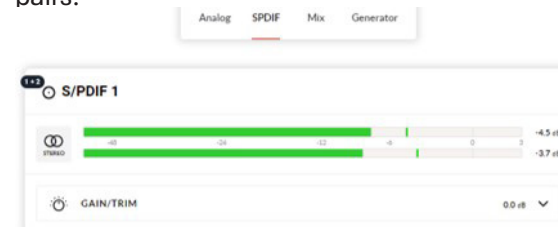

5.2c Input > MIX:

The mix tab is used for configuring signal levels in two independent mixes on two-channel amplifiers, or four mixes on four-channel amplifiers. All mixes have the four analog input signals and SPDIF input as available sources.

Once a mix has been set up, it can be used as a zone's primary input or priority input.



5.2d Input > Generator:

The signal generator produces a controlled audio signal that can be used in diagnostic or setup procedures, used as a zone source. (see [sec. 5.3a](#)) Available signals include an adjustable sinewave (20Hz-20kHz), or pink noise. Both have a gain range from 0dB to -48dB. Pink noise offers optional band-limited output using a sliding HP & LP filter.

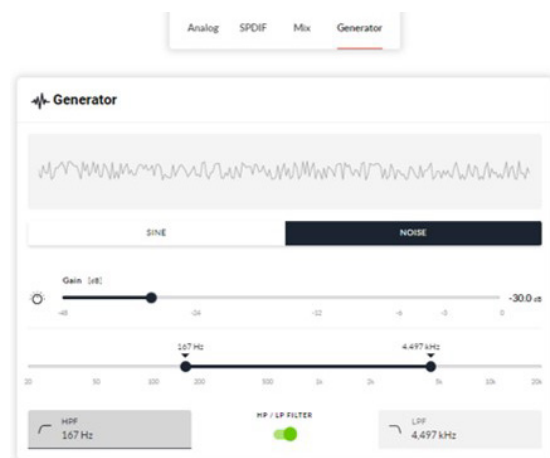

5.3 Zone

The zone tab enables zones to be defined and named. Once defined, a zone is typically routed to one or more amplifier output channels and wired to speakers covering a specific listening area.

The zone configuration menu has four sub-menus; zone source, zone volume, zone restrictions, and zone compressor.

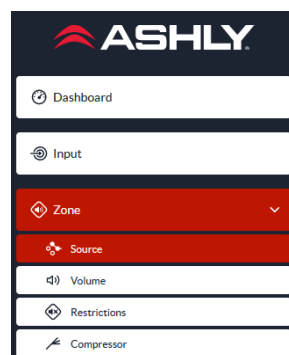

Configure each zone by first selecting one of the available zone identifiers at the top of the menu page, zone A or B in two channel amplifiers, or zone A, B, C, or D in four channel amplifiers.

Next, choose mono or stereo for that zone by selecting the button to the left of the zone's LED level display. If a stereo zone is selected, the same settings are applied to both channels.

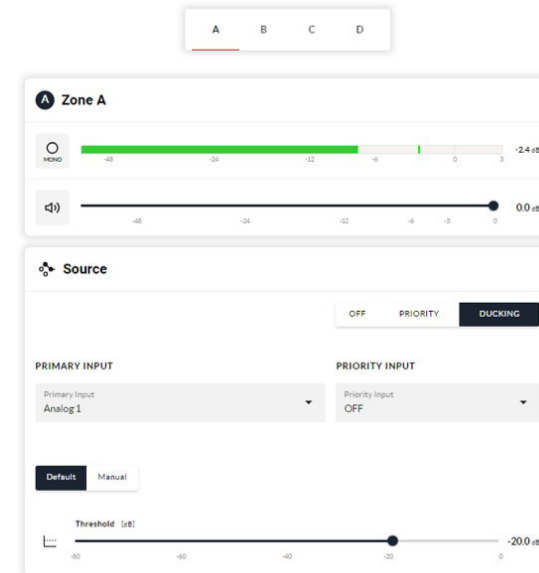

5.3a Zone > Source:

The zone source tab is for assigning a primary input for that zone, and if desired, assigning a priority or ducking input.

- The priority input signal will override and mute the primary input when its signal level exceeds the threshold setting. Priority input settings include threshold, attack time, hold time, and release time.
- The ducking input works the same as the priority input, but instead of muting the primary input, adds ducking depth control.

- Both primary and priority input source options include the following:
 - Any of the four analog inputs
 - S/PDIF inputs
 - The noise/sinewave generator
 - Mix1, Mix2, (Mix3 & 4 in 4ch amps)
- **Override Zone Volume:** If the priority input is enabled, selecting the Override Zone Volume checkbox causes the priority input signal, once it exceeds its threshold setting, to always override the current zone volume setting.

5.3b Zone > Volume:

The zone volume menu page offers control settings for min/max volume levels for the selected zone, as well as allowing the mute function for that zone.

Additionally, GPIO control for the selected zone is enabled from the zone volume menu. Control can be allowed from any of the amplifier's four GPIO pins as long as those pins have been set as a volume source. (see [sec. 7](#))

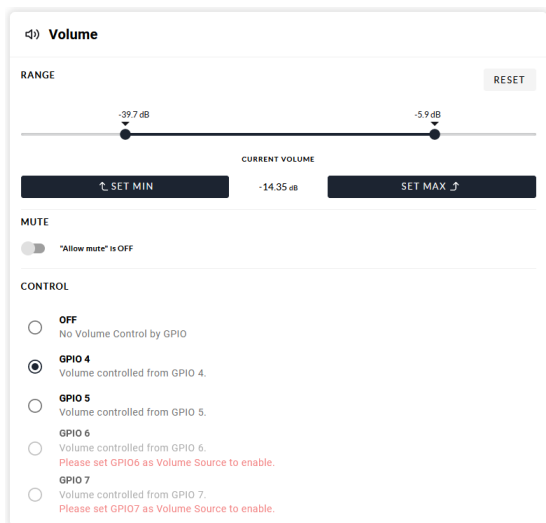

5.3c Zone > Restrictions:

The zone restrictions menu page is used to either allow or restrict input sources for the selected zone. Primary input sources set for the selected zone can not be restricted.

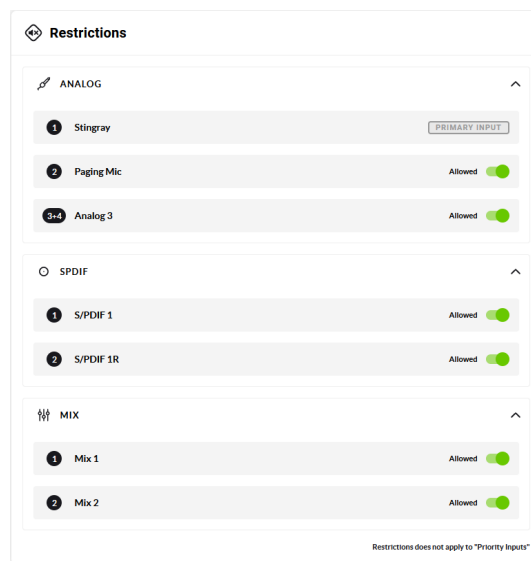

5.3d Zone > Compressor:

The zone compressor menu page (not shown) allows for default or manual signal compression settings to be applied to the selected zone. Includes On/Off.

Note: Compression can be useful to reduce the volume difference between loud and quiet audio material. The lower the compression threshold is set, the more the difference between loud and soft will be reduced. The overall zone volume may need to be increased when compression is used. The default compression parameters are appropriate for most installations.

5.4 Output

In the output tab, the number of speaker outputs available for configuration depends on the FX amplifier model (2 or 4 channel), and the input, zone and output mode configuration (mono or stereo). Select the output for configuration by highlighting one of the available output channels at the top of the output menu page.

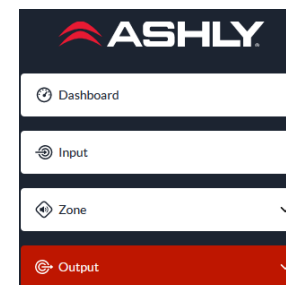

Every output menu page and submenu has a volume control, a 180° phase button, mute button, and a LED level display for the selected output.

Additional output tab submenus include the following:

5.4a Output > Routing:

The Routing menu assigns the zone source to be used for the selected output.

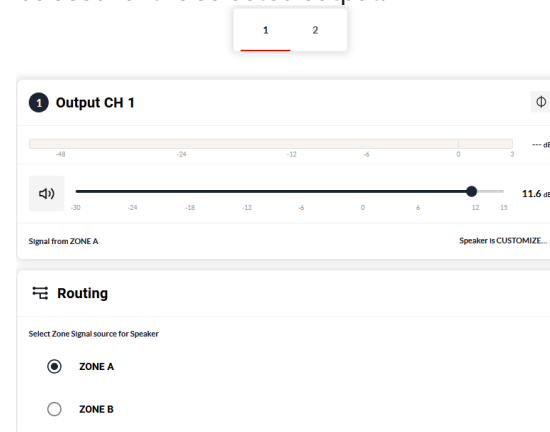

5.4b Output > Delay:

The Delay menu provides an output delay time of up to 100ms. Delay time can be set by feet, meters, or DSP samples. Includes On/Off.

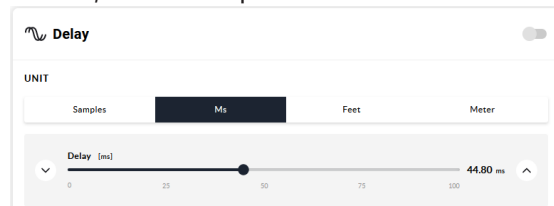

5.4c Output > Equalizer:

The Output Equalizer menu offers a 10-band parametric equalizer with 13 different filter types (see specifications) which can be applied to the selected output. Equalizer settings configured for one output can be copied and applied to another output channel. Includes master On/Off, and On/Off per filter.



5.4d Output > Speaker Presets

Within the Output tab, a Speaker Preset sub-menu allows custom configuration of parameters which can then be exported as a *.zcp speaker preset file. The *.zcp file is exported to the same download location used by your browser.

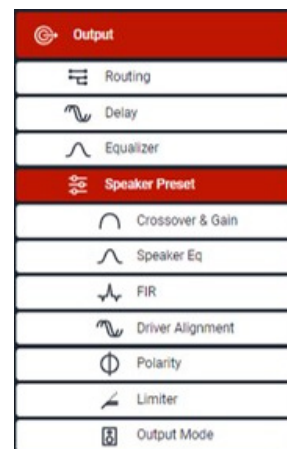

Speaker preset files can be added to a Speaker Library ([see sec. 5.5](#)) for repeated use later.

The following parameters can be individually edited, saved, and locked within a speaker preset file:

- **Crossover & Gain** menu enables high or low-pass crossover filters and gain adjustment to be applied to an amplifier output. Crossover filter settings configured for one amplifier output can be copied and applied to other outputs. Note: See the specifications section for a list of all available filter types and slopes.
- **Speaker EQ** menu enables several types of equalization to be applied to individual amplifier outputs following the application of crossover filtering. Equalizer settings configured for one amplifier output can be copied and applied to other outputs. Note: See the specifications section for a list of all available filter types.

- **FIR** menu enables importing of FIR filters up to 512 taps (coefficients).
- **Driver Alignment** menu offers time delay of up to 10ms to be applied to amplifier outputs following the application of crossover filtering. Delay time can be set by feet, meters, or DSP samples.
- **Polarity** menu enables the phase of the amplifier output to be inverted 180°.
- **Limiter** menu enables Clip, Peak, and RMS signal limiting to be applied to individual amplifier outputs.
- **Output Mode** menu enables individual amplifier outputs to be switched off or configured for Low-Z or Hi-Z modes.

In Hi-Z modes (70V or 100V), a high-pass filter can be enabled from 20Hz to 200Hz.

Note: Use of a high-pass filter with Hi-Z mode loudspeakers is useful to avoid the possibility of distortion caused by low frequency line transformer saturation. Begin with the default filter setting of 70Hz. If low frequency distortion is still audible, increase the frequency setting one step at a time until the distortion is no longer audible.

5.4e Speaker Preset files

After all speaker preset parameters have been configured, click "Export Preset To File" from the top level Speaker Preset menu. A final checkbox will appear, and only the selected speaker preset parameters will be exported. This creates a *.zcp file which will be saved to your browser's current download folder. From there, a *.zcp file can be imported into a speaker library for use later. ([sec. 5.5](#))

5.5 Settings Tab

The Settings Tab enables miscellaneous amplifier settings to be configured, installation site information to be recorded, and provides access to the following sub-menu items:

- **System Information** menu provides text fields for installation-specific data entry.
- **Device** menu displays specific amplifier information including model number, serial number, firmware version, MAC address, and WiFi MAC address.

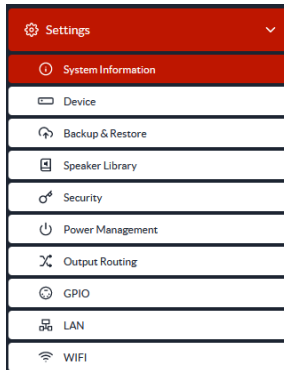

A firmware update routine and device identifier button are also found in the Device menu.

Note: The "Find Me" locator button in the Device menu will continually flash the amplifier's front panel LEDs in a unique pattern until the button is pressed again.

- **External Devices (FX firmware v1.6.8 or higher)** allows wired network pairing of an FX amplifier to one or more ashly [FXC wall-mount remote controllers](#). An FXC remote can be configured to control a single zone's analog input levels, S/PDIF input level, or mix level using a rotary encoder and graphic display screen. See the FXC manual for full details.

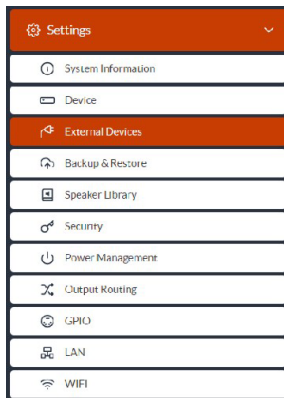

- **Backup & Restore** menu enables the complete amplifier configuration to be backed up to an external file, and enables previously saved backup files to be restored to the currently connected amplifier.

Also found in this menu is a Recovery button that will restart and reconnect the amplifier.

The Reset button will restore the unit to its factory default settings, *permanently erasing all data*.

- **Speaker Library** allows the user to create, edit, and import custom made or other provided speaker libraries.

1) Click on the Create button to create a new speaker library. Name the library and revision if desired. A library may contain several speaker series.

2) Select a Speaker Series, then use the  icon to import one or more *.zcp speaker preset files into that series. Note: *.zcp speaker preset files are created and exported using the Output>Speaker Preset menu.

3) To add another speaker series, click .

4) To rename a selected speaker series, click .

5) To delete a selected preset or series, click .

6) Click the Update button when complete, the library is now loaded to the amplifier and can be used in the Output>Speaker Preset menu for selecting a library speaker preset to an amplifier output. Note: It may be necessary to first clear an existing speaker preset before importing a new one.

7) To export a complete speaker library *.zcl file, click Export from the Speaker Library Create or Edit menus. The *.zcl file is exported to the same download folder that is used by the browser.

8) To import an existing speaker library *.zcl file, click the Speaker Library Import button.

- **Security** menu is where a password is assigned. The password will be required in order to log in to the software interface.

- **Power Management** menu enables various automatic standby and switch-on options to be engaged. A complete description of each Auto-On mode can be found in the Settings>Power Management menu.

In addition, the Power Management menu offers timed Standby and Mute functions.

Important Note: When Audio (Eco) or Trigger (Eco) Auto-On power management modes are selected, network communications will not function when the amplifier is in standby.

- **Output Routing** controls direct routing of an input source or zone output to the SPDIF output.

- **GPIO** menu enables configuration of the multi-purpose GPIO interface pins on the amplifier rear panel. See [section 7](#) for complete GPIO configuration details.

- **LAN** menu enables configuration and reset of the wired network options and parameters. See [sec 4.2](#) for details.

- **WiFi** menu enables configuration of the wireless network options and parameters. See [sec 4.2](#) for details.

6. Setup and Signal Routing

Thanks to their network based configuration features, FX amplifiers offer considerable versatility in terms of sources, signal routing, installation zones and output modes. Inputs can be freely assigned to installation zones, and those zones assigned freely to the available amplifier outputs in either Low-Z or Hi-Z modes.

This versatility enables, for example, one amplifier simultaneously to drive both Low-Z and Hi-Z speakers, or for different inputs to be routed to different output zones.

The following paragraphs describe and illustrate the recommended procedure for configuring zone and output routing. A general signal flow schematic is illustrated in [section 10](#).

6.1 Input Setup

- 1) Open the configuration Dashboard and select the Input Tab.
- 2) Select the Input Name field and enter text.
- 3) Define the input as mono or stereo by selecting the appropriate option. Defining a stereo input will reduce the total number of discrete inputs available.
- 4) Select an input sensitivity option from the drop-down menu: +14dB, +4dB, -10dB and 'microphone' options are available. Generally, the +14dB or +4dB options are appropriate for 'professional audio' source hardware with balanced outputs, while the -10dB option is more appropriate for 'consumer audio' source hardware with unbalanced outputs. The 'microphone' option provides the significantly greater sensitivity required for microphones.

Note: Only dynamic microphones are suitable for connection. Phantom power for condenser microphones is not provided.

- 5) If necessary, adjust the input gain using the slider or up/down icons. Gain adjustment is intended to be used for fine output level adjustment following initial use.

6.2 Zone Setup & Routing

- 1) Open the configuration Dashboard and select the Zone Tab.
- 2) Select the zone to be configured. The number of zones available will depend on the amplifier model, input setup (mono or stereo) and output mode (Low-Z or Hi-Z). For example, a two output amplifier will have two zones available if only mono inputs configured, but have only one zone available if any stereo input is configured. Similarly, a four output amplifier with only mono inputs configured but one output configured for Hi-Z mode will have only three zones available.

Note: When configured in Hi-Z mode, FX amplifiers operate in 'bridged' mode where the output of two channels is combined. This means that the number of output channels available in Hi-Z mode is half that available in Lo-Z mode.

- 3) Name the zone by entering text in the Zone Name field.
- 4) Adjust the zone volume if required by using the slider.
- 5) Define a mono or stereo zone by selecting the appropriate option. Defining a stereo zone will reduce the total number of further zones available.

6) Select the PRIMARY SOURCE and if override is required (such as for paging over background music), then select the PRIORITY SOURCE as well. The Priority and Ducking settings may be adjusted as needed. Note: Selecting a stereo input for a mono zone will automatically sum the stereo channels to mono.

7) Set up GPIO Volume Control for each zone if desired (see [sec. 7](#)). A minimum and maximum volume range can be set here.

8) Specify any restricted input sources that are not allowed in this zone.

10) Set up Compressor for each zone if desired.

6.3 Output Setup

- 1) Open the Dashboard Output Tab.
- 2) Select the output to be configured. The number of outputs available will depend on the amplifier model, zone setup and output mode. For example, a two output amplifier will have two outputs available if Low-Z mode is selected but only one output available if Hi-Z mode is selected.
- 3) Enter name into the Output Name field.

Note: Specifying a Zone as stereo will automatically generate three output channel source options: left channel, right channel or summed mono.

- 4) Select the Routing Source for each output
- 5) Set output delay if desired.
- 6) Set output EQ if desired.
- 7) Clear, create, import, or load a speaker preset file from the library if desired.

7. GPIO Setup and Connection

FX amplifiers offer a GPIO Euroblock socket that enables remote control of volume, standby, mute and trigger functions. (Diagram 7.3)

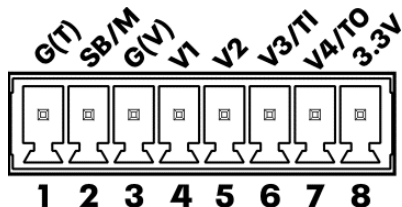

Some GPIO pins have multiple functions depending on their configuration. Each pin function is described below, as well as in the Settings>GPIO configuration menu.

- **Pin 1, Soft Ground**, use only for 12V trigger and standby/mute input reference.
- **Pin 2, Standby or Mute** (Diagram 7.1)
 - Off, Pin 2 has no functionality (default)
 - Standby (NO) Amplifier will enter Standby when Pin 2 is connected to Pin 1 GND.
 - Standby (NC) Amplifier will enter Standby when Pin 2 is unconnected (floating).
 - Mute (NO) All amplifier outputs are muted when Pin 2 is connected to Pin 1 GND.
 - Mute (NC) All amplifier outputs are muted when Pin 2 is unconnected (floating).
- **Pin 3, Ground**, use only as ground reference for GPIO Volume Control and Trigger Out.
- **Pin 4, GPIO Volume Control** (Diagram 7.2)
 - Off, Pin 4 has no functionality (default)
 - GPIO Volume Control, When selected, Pin 4 is available for remote volume control input assignment in Zone>GPIO Volume Control menu.

- **Pin 5, GPIO Volume Control** (Diagram 7.2)
 - Off, Pin 5 has no functionality (default)
 - GPIO Volume Control, When selected, Pin 5 is available for remote volume control input assignment in Zone>GPIO Volume Control menu.

- **Pin 6, Volume Control or 12V Trigger In**
 - Off, Pin 6 has no functionality (default)
 - GPIO Volume Control, When selected, Pin 6 is available for remote volume control input assignment in Zone>GPIO Volume Control menu. (Diagram 7.2)
 - 12V Trigger In, Amplifier will operate when 12V signal is applied to Pin 6, and will enter Standby when no voltage is applied. Note: This requires Trigger-Mode to be selected in the Settings>Power Management menu

- **Pin 7, Volume Control or 12V Trigger Out**
 - Off, Pin 7 has no functionality.
 - GPIO Volume Control, When selected, Pin 7 is available for remote volume control input assignment in Zone>GPIO Volume Control menu. (Diagram 7.2)
 - 12V Trigger Out, When selected, Pin 7 provides 12V for use with Trigger Input function on Pin 6. (default)

- **Pin 8, 3.3V power**, use for GPIO volume controls. Note: GPIO Pin 8 has an output impedance of 1kΩ. Connected devices must be able to sink 3.3mA.

Note: The GPIO connector must not be used for any unintended purpose. Amplifier damage may result from incorrect use of GPIO pins. Shielded cable must be used when connecting standby switches and potentiometers via GPIO pins.



Diagram 7.1: GPIO Connections for remote standby/mute switch

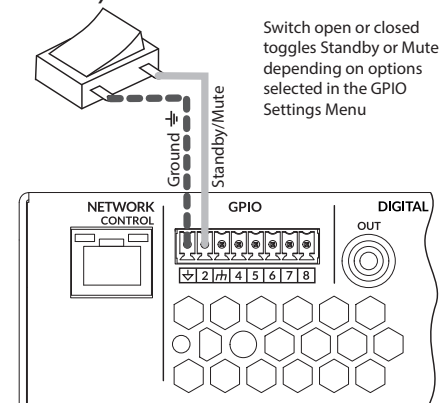

Diagram 7.2: GPIO Potentiometer connections for remote volume control. Use Ashly WR-1 or WR-1.1 wall remote or equivalent circuit.

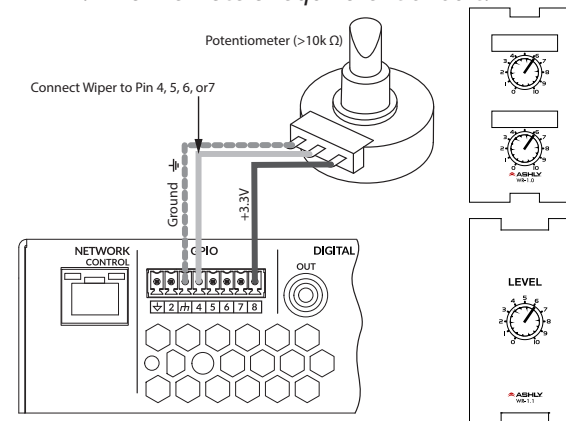
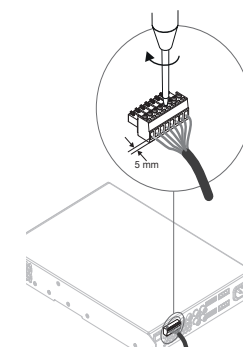

Diagram 7.3: GPIO connections



8. Connections

8.1 Mains Power Connection

FX amplifiers incorporate a power factor corrected universal power supply and can be used with mains input voltage from 100VAC to 240VAC, 50/60Hz. Use the mains cable supplied with the amplifier.

FX *half-rack* amplifiers have no mains power switch and are operational as soon as mains power is connected. Ensure that all signal, GPIO and output connections are made before connecting the amplifier to mains power.

8.2 Input Connections

All FX amplifier models provide four balanced or unbalanced analog audio inputs and a stereo S/PDIF digital audio input. Any input channel can be routed to any zone using the Zone>Source menu. See Sections [6.2](#) or [5.3](#).

Analog Inputs

FX analog inputs are of line level format with a default input sensitivity of +4dBu (full output voltage swing/sensitivity) in all output modes. Input signal levels up to +24dBu can be handled without input clipping. Input sensitivity options are set via the amplifier network interface Input>Sensitivity menu. See Sections [6.1](#) or [5.2](#).

- Balanced input connections to the amplifiers are made via male 'Euro Block' connectors. Connecting cables to the supplied female input connectors is illustrated in Diagram 8.2.
- Unbalanced input connections to the amplifiers are made via RCA phone jacks.

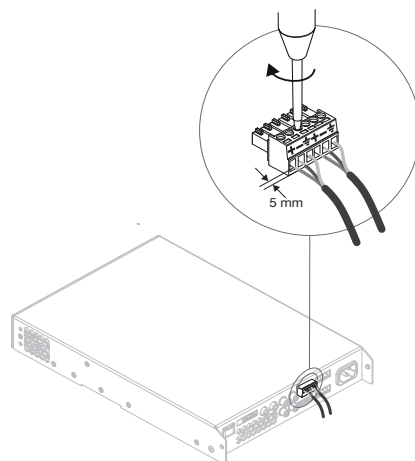
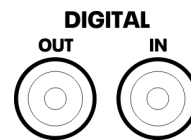

Diagram 8.2: Balanced Input connections

Note: 2 channel amplifier model connections differ from 4 channel models only in the deletion of channel 3 and channel 4 output connectors. Input and GPIO connections remain the same between all FX models.

Digital Input/Output

FX amps offer S/PDIF stereo digital audio input via one RCA Phone jack.



The S/PDIF stereo output signal routing is fully configurable in the "Settings > Output Routing" menu. Source options for each S/PDIF output channel include Analog input, S/PDIF input, Zone, or Mix.

S/PDIF output routing can extend one FX amp's zone, input, or mix to one or several additional amps. **NOTE: there is a 1.1ms delay in a S/PDIF out-to-in connection.**

75Ω RCA Phono cables specifically intended for digital audio should always be used for S/PDIF connections. Standard Phono cables can be used but may not result in optimal performance.

8.3 Output Speaker Connections

Output connections from the amplifiers are achieved via male 'Euro Block' connectors. Ensure that speaker connection polarity is correct throughout the installation:

- In the case of Low-Z speaker connections, positive (+) amplifier terminals should always be connected to positive speaker terminals and negative (-) amplifier terminals always connected to negative speaker terminals.

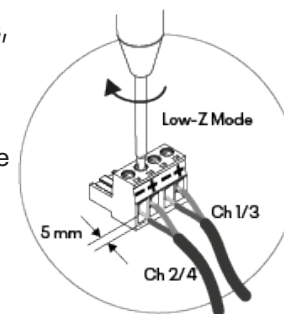

- In the case of Hi-Z (70V or 100V) speaker connections, the two speaker cable conductors should be connected between the positive (+) terminal of Output 1 and the negative terminal (-) of Output 2, and likewise for Outputs 3 and 4.

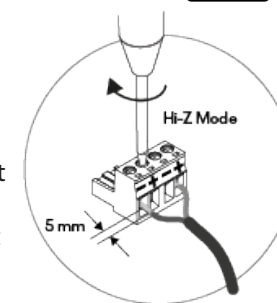

- *Output mode options (Low-Z or Hi-Z) are configured via the amplifier network interface in the Output>Speaker Preset>Output Mode menu.*

Note: The exclamation point printed next to the output terminals of the amplifiers is, in addition to the CLASS 2 WIRING text, intended to alert users to the risk of hazardous voltages. Output connectors that could pose a risk are marked with the exclamation point. Do not touch the output terminals while the amplifier is switched on. Make all connections with the amplifier switched off. See [Section 8.1](#) of this manual.

8.4a Speaker Cable Gauge (FX60 & FX125 models)

FX speaker connection cable gauge should be chosen appropriately to reflect the type of installation. The following tables specify the appropriate cable gauge for less than 0.5dB cable loss with different installation types and cable lengths.

FX60 & FX125 Amplifier Cable Gauge Table: Low-Z installations. 4Ω & 8Ω loads

Cable Cross Section (mm ²)	Cable Gauge (AWG)	Max Cable Length in meters (ft), 4Ω load	Max Cable Length in meters (ft), 8Ω load
0.5	≈20	2, (7ft)	5, (16ft)
0.8	≈18	4, (13ft)	8, (26ft)
1.3	≈16	6, (20ft)	12, (39ft)
2.1	≈14	9, (30ft)	19, (62ft)
3.3	≈12	14, (46ft)	30, (98ft)

FX60 & FX125 Cable Gauge Table: 70V Hi-Z installations

Cable Cross Section (mm ²)	Cable Gauge (US)	Max Cable Length in meters (ft), 125W/channel	Max Cable Length in meters (ft), 250W/channel
0.5	≈20	84, (276ft)	42, (138ft)
0.8	≈18	132, (433ft)	66, (217ft)
1.3	≈16	210, (689ft)	105, (345ft)
2.1	≈14	334, (1,096ft)	166, (545ft)
3.3	≈12	532, (1,745ft)	265, (869ft)

FX60 & FX125 Cable Gauge Table: 100V Hi-Z installations

Cable Cross Section (mm ²)	Cable Gauge (US)	Max Cable Length in meters (ft), 125W/channel	Max Cable Length in meters (ft), 250W/channel
0.5	≈20	171, (561ft)	85, (279ft)
0.8	≈18	269, (883ft)	134, (440ft)
1.3	≈16	430, (1,411ft)	215, (705)
2.1	≈14	683, (2,241ft)	341, (1,119ft)
3.3	≈12	1087, (3,566ft)	542, (1,778ft)

8.4b Speaker Cable Gauge (FX500 & FX750 models)

FX speaker connection cable gauge should be chosen appropriately to reflect the model and type of installation. The following tables specify the appropriate cable gauge for less than 0.5dB cable loss in Lo-Z mode, and less than 1.0dB cable loss in Hi-Z modes.

FX500 & FX750 Amplifier Speaker Cable Gauge Table: Low-Z installations, 0.5dB attenuation, 2Ω, 4Ω, & 8Ω loads

Cable Cross Section (mm ²)	Cable Gauge (AWG)	Max Cable Length in meters (ft), 2Ω load	Max Cable Length in meters (ft), 4Ω load	Max Cable Length in meters (ft), 8Ω load
0.8	≈18	N/A	5, (16ft)	10, (33ft)
1.3	≈16	5, (ft)	10, (33ft)	20, (66ft)
2.1	≈14	8, (ft)	17, (56ft)	35, (115ft)
3.3	≈12	14, (ft)	28, (92ft)	55, (180ft)

FX500 & FX750 Amplifier Speaker Cable Gauge Table: 70V Hi-Z installations, 1.0dB attenuation, 20 speakers evenly distributed.

Cable Cross Section (mm ²)	Cable Gauge (AWG)	Max Cable Length in meters (ft), 1000W (bridged)	Max Cable Length in meters (ft), 1200W (bridged)
0.8	≈18	25, (82ft)	20, (66ft)
1.3	≈16	50, (164ft)	40, (131ft)
2.1	≈14	80, (262ft)	60, (197ft)
3.3	≈12	125, (410ft)	100, (328ft)

FX500 & FX750 Amplifier Speaker Cable Gauge Table: 100V Hi-Z installations, 1.0dB attenuation, 20 speakers evenly distributed.

Cable Cross Section (mm ²)	Cable Gauge (AWG)	Max Cable Length in meters (ft), 1000W (bridged)	Max Cable Length in meters (ft), 1500W (bridged)
0.8	≈18	50, (164ft)	30, (98ft)
1.3	≈16	100, (328ft)	60, (197ft)
2.1	≈14	160, (525ft)	100, (328ft)
3.3	≈12	250, (820ft)	160, (525ft)

9. Operation

Once all connections have been made and configuration options selected, FX amplifiers are ready for use. If an input signal above -60dB is present on any input, the front panel Input and Standby indicators will illuminate green to indicate normal amplifier operation. Audio will be heard from any connected speakers.

Note: FX amplifiers will not switch on from Standby Mode unless an input signal is present or a network or external standby switch is operated.

Amplifier outputs will mute if no input signal is present for 5 minutes, and the amplifier will switch automatically to Standby Mode if no signal is present on any input for more than 15 minutes. Alternative standby and mute delay times can be selected in the Settings>Power Management menu. Amplifier cooling fan speed is temperature controlled. The fan will switch off when the amplifier enters standby mode.

9.1 Front Panel LEDs

FX amplifier front panel indicators illuminate to indicate the following operational states:

- Status
- Input
- Output
- Network
- WiFi

- **Status**
 - Off** – Mains power disconnected.
 - Green** – Amplifier operational.
 - Pulse Green** – Standby Mode.
 - Amber** – GPIO triggered Standby Mode

- **Input**
 - Off** – No input signal present.
 - Green** – Signal present on one or more inputs.
 - Amber** – Signal limiting/clipping on one or more inputs.
- **Output**
 - Off** – No output signal present.
 - Green** – Signal present on one or more outputs.
 - Amber** – Signal limiting/clipping on one or more outputs.
 - Red** – One or more channel pair is in overload/protection mode.
- **Network**
 - Off** – No Ethernet network detected.
 - Green** – Ethernet network detected.
- **WiFi**
 - Off** – WiFi disabled.
 - Green** – WiFi enabled.

9.2 Automatic Power Sharing

FX60 and FX125 amplifier models incorporate a power sharing feature that automatically shares the total power available from the amplifier's internal power supply across each pair of output channels. If one channel temporarily demands more than the amplifier's continuous power rating while other channel is demanding less, the excess power available from the internal power supply is automatically made available to the over-power channel.

Power sharing optimizes the amplifier's ability to deliver maximum power into dynamic loudspeaker loads when playing music program material.

Note: Power-sharing is optimized for the 1/2U models. On 2RU models, the amount of power that may be shared is significantly lower.

9.3 Factory Reset

Use one of the following methods for FX reset:

- **Restart Device (software):** In the configuration Settings> Backup & Restore menu, there is a button called Restart Device. Performing a Device Restart does not erase any presets or data from the FX amplifier.
- **Full Reset (software):** In the configuration Settings> Backup & Restore menu, there is a button called **RESET!** Clicking this button will permanently erase all device data and restore the unit to factory defaults. It cannot be undone.
- **Factory Reset Switch:** On FX60 & FX125, there is a small opening in the chassis bottom center, just behind the front panel. This provides access to a recessed switch for factory reset. On FX500 & FX750 models, the front power switch is used in lieu of the bottom reset switch.

To perform a factory reset, remove AC power. Press and hold the reset switch, then apply AC power back to the unit. Hold the switch down for three seconds, then release the switch. This resets the unit to factory settings. **Do not hold for more than 5 sec.**

- **Rescue Mode:** When holding the reset switch in for a full 10 seconds, while applying main power to the amp, the amplifier will enter "Rescue Mode". **This will clear the amp of its firmware, rendering the amplifier inoperable.** The amplifier firmware will then need to be re-installed. This is done by connecting to the amplifier (WiFi or cabled), where the software user interface will now indicate that the amplifier is in Rescue Mode. From here, upload the latest Ashly FX firmware file using the Settings Tab > Device Menu (see [sec. 5.5](#)). Once uploaded, the amplifier is fully reset and will return to normal operation.



Diagram 10.1:
FX Front & Back Panels,
(FX125.4 shown)

Note: 2-Channel models are the same as 4-channel models other than power ratings and number of available zones and speaker outputs. All Network, Input, GPIO connections, and functionality are the same between FX models.

NOTE: FX500 & FX750 full-rack models (not shown) share the same features and connections as half-rack models.

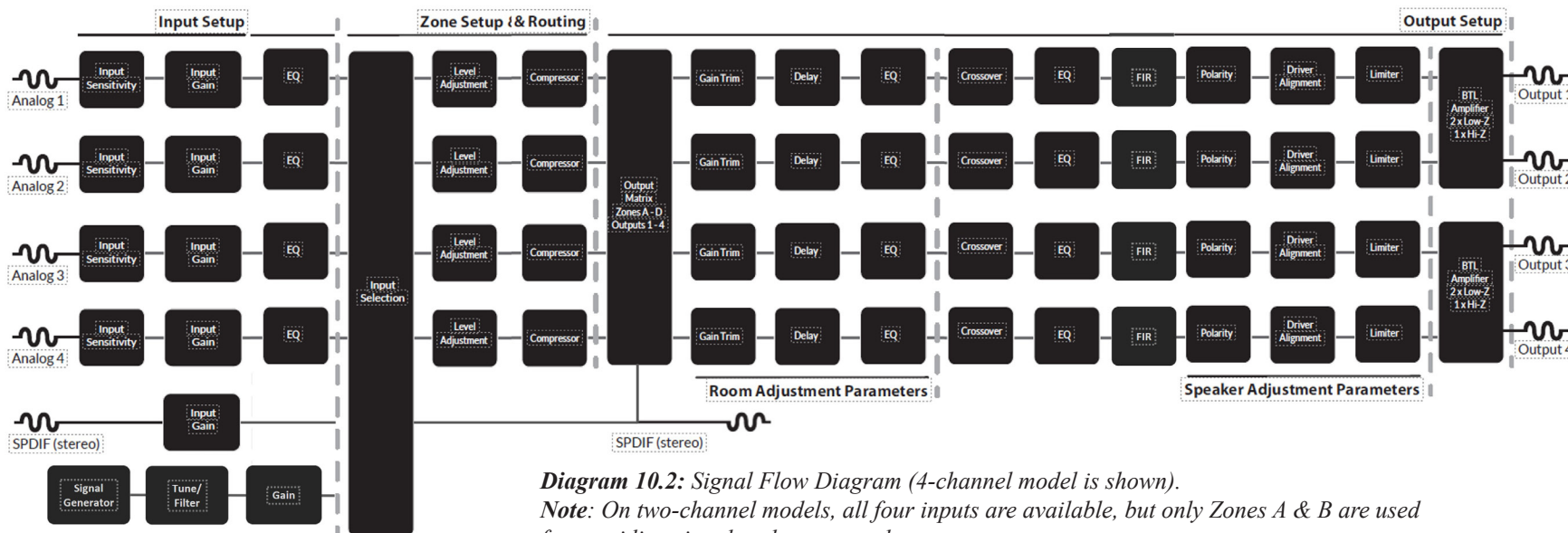
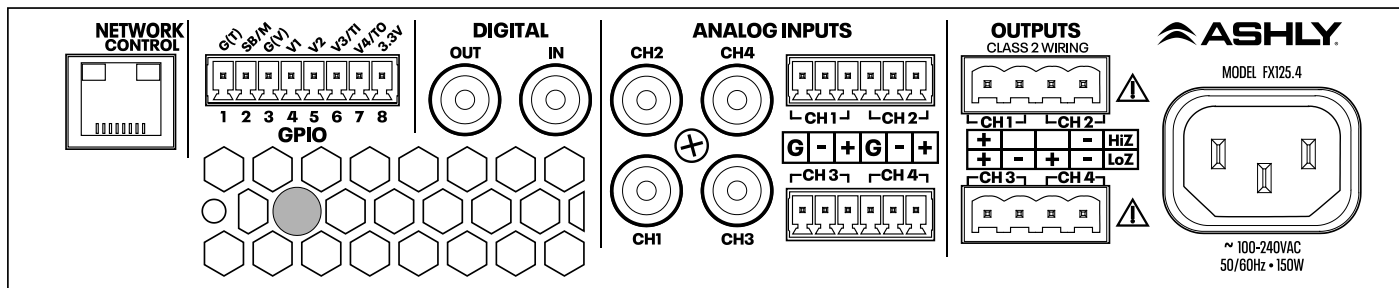

Diagram 10.2: Signal Flow Diagram (4-channel model is shown).

Note: On two-channel models, all four inputs are available, but only Zones A & B are used for providing signal to the two speaker outputs.

Note: On all FX models, the S/PDIF Out signal can be sourced from analog inputs, SPDIF input, Mix outputs, or Zones A - D using the "Settings > Output Routing" menu.

Model	FX 60.2	FX 125.2	FX 60.4	FX 125.4
Outputs	2 Low-Z or 1 Hi-Z	2 Low-Z or 1 Hi-Z	4 Low-Z or 2 Hi-Z	4 Low-Z or 2 Hi-Z
Output power @ 4Ω/8Ω/25V†/70V/100V* All channels driven	60W Low-Z 120W Hi-Z	125W Low-Z 250W Hi-Z	60W Low-Z 120W Hi-Z	125W Low-Z 250W Hi-Z
Output power @ 4Ω/8Ω/25V†/70V/100V* Single channel driven	120W**	250W** (156W)†	250W** (156W)†	250W** (156W)†
Output power @ 16Ω*** Single channel driven	120W	125W	125W	125W
Operational Power Consumption (1/8th Full Power, 4Ω Load)	33W	54W	59W	107W
Thermal Output (BTU/hr, 1/8th Full Power, 4Ω Load)	61	78	98	152
Dimensions	44 x 220 x 213 mm (1.7 x 8.7 x 8.4 in)	44 x 220 x 213 mm (1.7 x 8.7 x 8.4 in)	44 x 220 x 319 mm (1.7 x 8.7 x 12.6 in)	44 x 220 x 319 mm (1.7 x 8.7 x 12.6 in)
Weight	2.0 kg (4.4 lbs)	2.0 kg (4.4 lbs)	2.8 kg (6.2 lbs)	2.8 kg (6.2 lbs)
Output Circuitry	Class D - full bandwidth PWM modulator with ultra-low distortion			
Output Voltage	70 Vp / 140 Vpp (unloaded) / Bridged 140 Vp / 280 Vpp (unloaded)			
Signal To Noise-Ratio	> 106 dB (A-weighted 20 Hz - 20 kHz 8 Ω load)			
THD+N (typical)	< 0.05 % (20 Hz - 20 kHz 8 Ω load 12.5% rated power)			
Frequency Response	20 Hz - 20 kHz (+0/-0.25 dB (8 Ω load 12.5% rated power)			
Protection Circuits	Short circuit protection. DC protection. under voltage protection. temperature protection. overload protection			
Power Supply	Universal mains switch mode power supply with Power Factor Correction (PFC) and integral standby converter			
Operating Voltage/ Frequency	Universal Mains 100-240V 50-60Hz			
Standby Consumption	< 0.5W			
Accessories (sold separately)	FA1.2RM rack ear, half-rack extension, connection plate; FA2.2RM rear-support kit; FATWB desk/wall mount kit, WR-1 & WR-1.1 GPIO Remote Volume Control			
Power Ratings	1% THD @ 120VAC and 230VAC			

* 100V line mode operates at 90V (~-1dB)

** Power sharing operational (FX60 and FX125 models only)

*** 16 Ohm power output is limited by the maximum voltage swing available in low impedance mode

† For 25V applications, maximum power with power sharing is 156W. Output load must be >4Ω

Model	FX 500.2	FX 750.2	FX 500.4	FX 750.4
Output Channels	2 Low-Z or 1 Hi-Z	2 Low-Z or 1 Hi-Z	4 Low-Z or 2 Hi-Z	4 Low-Z or 2 Hi-Z
Output power @ 2Ω	2 x 500W (Single Ch)*	2 x 750W (Single Ch)*	4 x 500W (Single Ch)	4 x 750W (Single Ch)
Output power @ 4Ω	2 x 500W (Single Ch) 1 x 1000W (Bridged)**	2 x 750W (Single Ch) 1 x 1500W (Bridged)**	4 x 500W (Single Ch) 2 x 1000W (Bridged)	4 x 750W (Single Ch) 2 x 1500W (Bridged)
Output power @ 8Ω	2 x 250W (Single Ch) 1 x 1000W (Bridged)	2 x 400W (Single Ch) 1 x 1500W (Bridged)	4 x 250W (Single Ch) 2 x 1000W (Bridged)	4 x 400W (Single Ch) 2 x 1500W (Bridged)
Output power @ 25V†	2 x 320W (Single Ch)†	2 x 320W (Single Ch)†	4 x 320W (Single Ch)†	4 x 320W (Single Ch)†
Output Power @ 70V	1 x 1000W (Bridged)	1 x 1200W (Bridged)	2 x 1000W (Bridged)	2 x 1200W (Bridged)
Output Power @ 100V	1 x 1000W (Bridged)	1 x 1500W (Bridged)	2 x 1000W (Bridged)	2 x 1500W (Bridged)
Total System Power	1000W	1500W	2000W	3000W
Operational Power Consumption (1/8th Full Power, 2Ω Load)	191W	275W	378W	545W
Thermal Output (BTU/hr, 1/8th Full Power, 2Ω Load)	225	298	436	580
Output Voltage	65Vp/130Vpp (single Ch unloaded) 130Vp/260Vpp (Bridged unloaded)	65Vp/130Vpp (single Ch unloaded) 130Vp/260Vpp (Bridged unloaded)	65Vp/130Vpp (single Ch unloaded) 130Vp/260Vpp (Bridged unloaded)	65Vp/130Vpp (single Ch unloaded) 130Vp/260Vpp (Bridged unloaded)
Weight	5.9 kg (13 lbs)	5.9 kg (13 lbs)	7.4 kg (16.3 lbs)	7.4 kg (16.3 lbs)
Dimensions	88 x 440 x 332 mm (3.5 x 17.3 x 13.1 in)			
Output Circuitry	Class D - full bandwidth PWM modulator with ultra-low distortion			
Output Voltage	70 Vp / 140 Vpp (unloaded) / Bridged 140 Vp / 280 Vpp (unloaded)			
Signal To Noise-Ratio	> 108 dB (A-weighted 20 Hz - 20 kHz 8 Ω load)			
THD+N (typical)	< 0.05 % (20 Hz - 20 kHz 8 Ω load 3dB below rated power)			
Frequency Response	20 Hz - 20 kHz (+0/-0.5 dB (8 Ω load 3dB below rated power)			
Protection Circuits	Short Circuit, Output DC, Undervoltage, Temperature, Overload protection			
Power Supply	Universal mains switch mode power supply with Power Factor Correction (PFC) and integral standby converter			
Operating Voltage	Universal Mains, 100-240V, 50Hz-60Hz			
Standby Consumption	< 0.5W			
Accessories	2x rack ears, 4x adhesive feet (included), WR-1 & WR-1.1 GPIO Remote Volume Control (sold separately)			
Power Ratings	1% THD @ 120VAC and 230VAC			

Dashboard Menu	
Amplifier Status	Power/Standby, Input, Output, Wired LAN IP address, WiFi IP address
Zone Status	Mute per zone, Gain adjust -80dB to 0dB, Input Type, Output Routing
Input Menu	
Analog Inputs 1-4	Per Input: Mono/Stereo; 100Hz HPF; Sensitivity (Mic, -10dBV, +4dBu, +14dBu; Gain/Trim control -15dB to +15dB; 5-Band EQ
S/PDIF Inputs	Mono/Stereo; Gain/Trim (-15dB to +15dB)
Mix	Per Available Mix: Analog Input 1-4, SPDIF Input level control (-inf. to 0dBu)
Generator	Sinewave (20Hz-20kHz); Noise Generator (HP & LP filters with On/Off, 20Hz-20kHz); Level control (-48dB to 0dB)
Zone Menu	
Source	Zone A/B in 2ch models, Zone A-D in 4ch models, Gain adjust per zone -80dB to 0dB, Mono or Stereo, Zone Input Source Select
GPIO Volume Control	Per Zone; On/Off; Min/Max remote volume limit; GPIO Pins must be enabled for Volume Control
Restrictions	Per Zone; Analog inputs, SPDIF inputs, & Mix inputs can be individually allowed or restricted from use in the selected zone
Compressor	Per Zone; On/Off; Default or Manual Mode; Manual mode parameters (Threshold, Attack, Release, Hold, Ratio, Knee)
Output Menu	
Routing	Zone source selection per output 1-2 on 2ch models, outputs 1-4 on 4ch models
Delay	Per output, ON/OFF, adjustable 0-100ms (feet, meters, & samples also indicated)
Equalizer	10-Band Per output, ON/OFF, Edit, Copy, Clear
Filter Types	Parametric, 6dB Hi/Lo Shelf, Hi/Lo Shelf with Q, 6dB & 12 dB LPF/HPF, 1st & 2nd order All Pass, Bandpass, Notch
Speaker Preset	Per output, select preset from library, import preset from file, export preset to file, clear preset
Crossover & Gain	Per Speaker Preset, ON/OFF, Gain, Copy, Clear, High Pass Filter, Low Pass Filter
Filter Types	Off, Butterworth 6/12/18/24/36/48dB/octave, Bessel 12/24/48dB/octave, Linkwitz-Riley 12/24/36/octave
Speaker EQ	Per Speaker Preset, 15-Band EQ Per Preset, ON/OFF, Edit, Copy, Clear
Filter Types	Parametric, 6dB Hi/Lo Shelf, Hi/Lo Shelf with Q, 6dB & 12 dB LPF/HPF, 1st & 2nd order All Pass, Bandpass, Notch
FIR Filters	Per Speaker Preset, ON/OFF, Import, Clear (512 taps maximum)
Driver Alignment	Per Speaker Preset, ON/OFF, adjustable 0-10ms (feet, meters, & samples also indicated)
Polarity	Per Speaker Preset, 0°, 180°
Limiter	Per Speaker Preset, Clip Limiter ON/OFF, Peak Limiter (Auto/Manual mode), RMS Limiter ON/OFF
Output Mode	Per Speaker Preset, Off, Lo-Z (4 & 8 Ohm); Hi-Z 70V; Hi-Z 100V (Hi-Z Modes require two output channels)

Settings Menu	
System Information	Installation site info
Device	Device info, device locator, firmware update
External Devices (FXC)	Refresh, Add by IP, Show paired/unpaired devices, Amp shut-down, Device & Network info, Visual settings, Lock enable
Backup & Restore	Backup/restore device settings from file, restart device, factory reset
Speaker Library	Create/Edit/Import speaker libraries
Security	Password Entry; Enabled; Disabled
Power Management	Set Auto-On options (Audio (Eco), Audio, Trigger (Eco), Trigger, Network Only); Change Standby timer, Change Mute timer
SPDIF Output Routing	Source: Analog inputs 1-4, SPDIF input 1-2, Mix outputs, Zone A-B (2ch models), Zone A-D (4ch models)
GPIO Connector	GPIO Pin assignment options
Pin 1	Soft ground only, use for 12V trigger and standby/mute input reference
Pin 2	Off; Standby (NO); Standby (NC); Mute (NO); or Mute (NC)
Pin 3	Ground, use as reference for Voltage Control and Trigger Out
Pin 4	Off; When selected the pin is used for external Volume Control
Pin 5	Off; When selected the pin is used for external Volume Control
Pin 6	Off; 12V Trigger Input (requires Trigger-Mode be selected in Power Management section); external Volume Control
Pin 7	Off; 12V Trigger Out; External Volume Control
Pin 8	Power 3.3 (use for external volume control)
LAN	Set LAN network mode to DHCP or Static IP. The wired LAN default static IP address is 192.168.64.100
WiFi	WiFi ON/OFF, Disable WiFi on LAN connection, WiFi Disable timer, set WiFi mode to Access Point (hot spot) or to Client. The FX amplifier's WiFi access point (hotspot) IP address is 192.168.4.1, default password is "password"

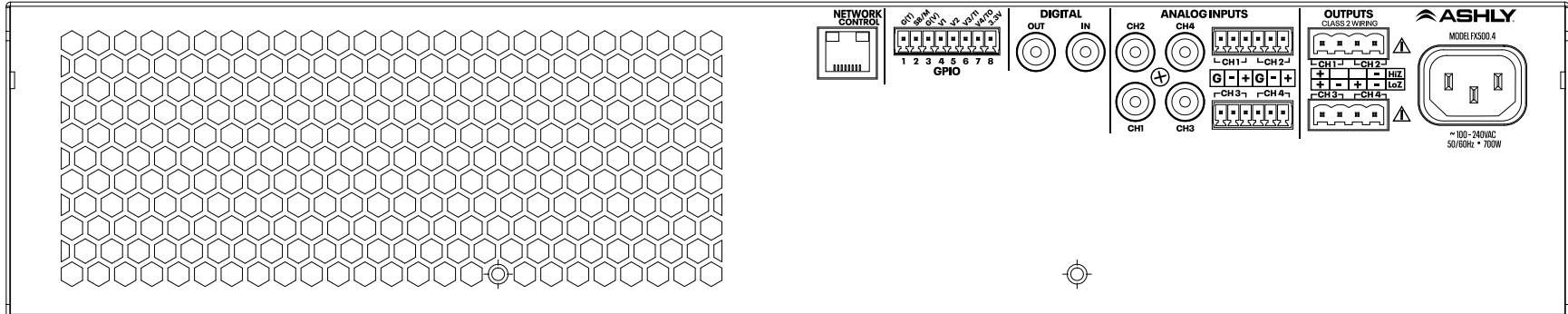

FX500 & FX750 models (4ch)

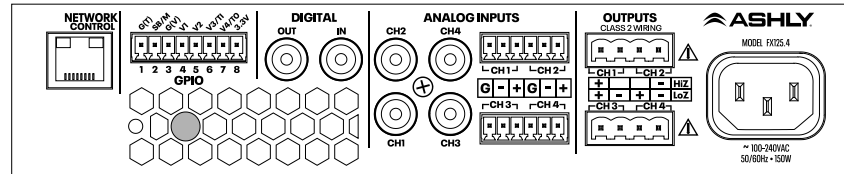

FX60 & 125 models (4ch)

13. FXC Remotes

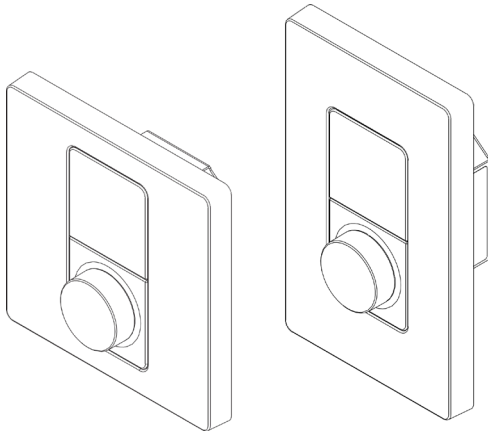

Device Description

FXC remotes (sold separately) are programmable graphic display wall-mount devices designed for remote control of input & zone mix volume, source selection, and power/standby on a connected Ashly FX amplifier.

FXC remotes are designed to mount into a standard North America or EU electrical box.

Each FXC device can control one zone only. For example, the remote control of four zones would require four devices – each assigned to one of the 4 individual zones.

Multiple FXC devices can be assigned to the same zone, although it is not recommended to connect more than eight FXC devices per FX amplifier.

FXC remotes can be pass-code protected for security.

FXC Remote Requirements

IMPORTANT! FXC remotes are only compatible with Ashly FX Amplifiers running firmware version 1.6.8 or higher. Be sure to verify/update the firmware installed on the Ashly FX amplifier to v1.6.8 or higher before attempting to install and configure FXC devices. Visit <https://ashly.com/firmware-updates/> to obtain the latest FX firmware.

Note that the FXC is not self-powered. Power is supplied to the device with the use of a standard PoE Switch (or PoE injector) and Cat5 cable (or above).

The illustration below outlines how to connect multiple FXC devices to an Ashly FX amplifier, via the use of a standard PoE network switch and Cat5 cable.

Pairing the FXC remote to an amplifier is done in the FX web app's "Settings> External Devices" section (FX firmware v1.6.8 or higher).

See the Ashly FXC manual for complete details on connecting, pairing, setting up, and configuring an FXC remote with an FX amplifier.

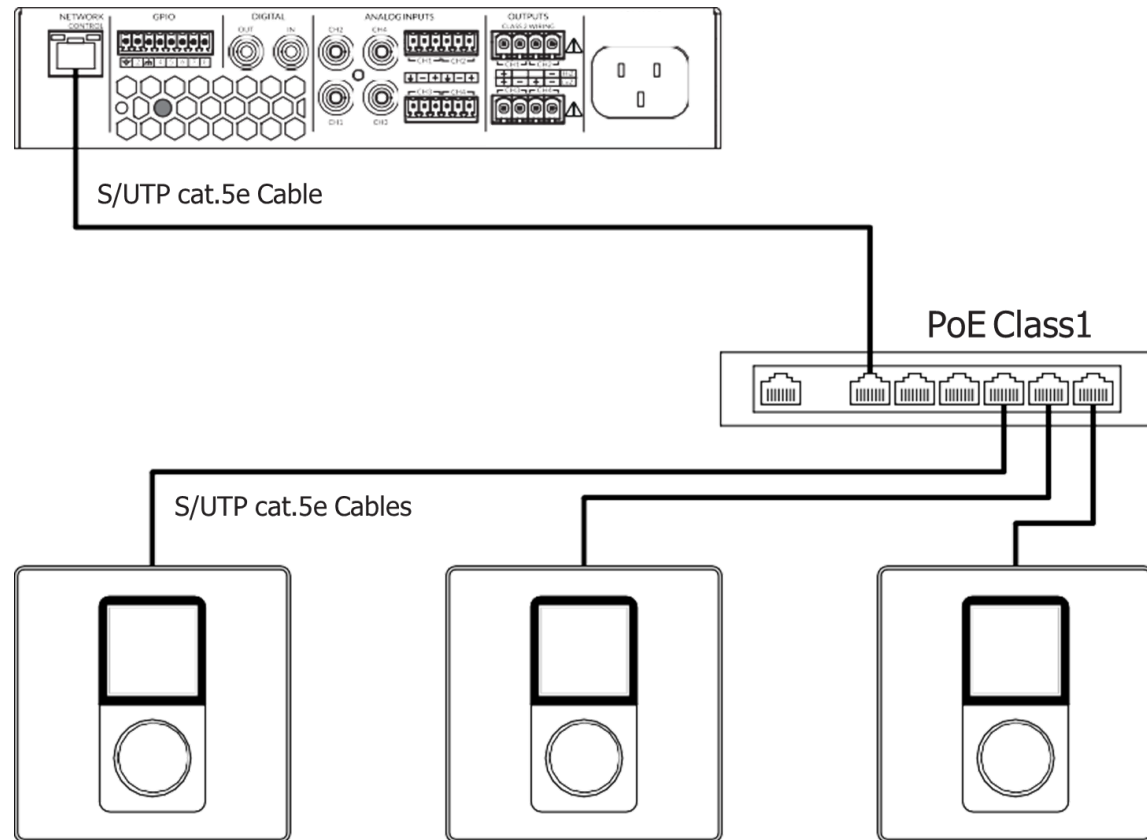

LIMITED WARRANTY (USA ONLY)

(Other countries please contact your respective distributor or dealer.)

For units purchased in the USA, warranty service for this unit shall be provided by ASHLY AUDIO in accordance with the following warranty statement.

ASHLY AUDIO, an **exertis|JAM** business, warrants to the owner of this product that it will be free from defects in workmanship and materials for a period of FIVE years from the original-date-of-purchase, with the exception of touch-screen displays and motorized faders which are warranted for THREE years from the original-date-of-purchase.

ASHLY AUDIO will without charge, repair or replace at its discretion, any defective product or component parts upon prepaid delivery of the product to the ASHLY AUDIO factory service department, accompanied with a proof of original-date-of-purchase in the form of a valid sales receipt. This warranty gives you specific legal rights, and you may also have other rights, which vary from state to state.

EXCLUSIONS: This warranty does not apply in the event of misuse, neglect, or as a result of unauthorized alterations or repairs made to the product. This warranty is void if the serial number is altered, defaced, or removed. ASHLY AUDIO reserves the right to make changes in design, or make additions to, or improvements upon, this product without any obligation to install the same on products previously manufactured.

Any implied warranties, which may arise under the operation of state law, shall be effective only for FIVE years (THREE years for touch-screen displays and motorized faders) from the original-date-of-purchase of the product. ASHLY AUDIO shall be obligated to only correct defects in the product itself. ASHLY AUDIO is not liable for any damage or injury, which may result from, or be incidental to, or a consequence of, such defects. Some states do not allow limitations on how long an implied warranty lasts, or the exclusion, or limitation of incidental or consequential damages, so the above limitations or exclusions may not apply to you.

OBTAINING WARRANTY SERVICE:

For warranty service in the United States, please follow this procedure:

1) Contact the Ashly Service Department at 800-705-2102 or <https://ashly.com/technical-support/> to receive an RMA number. You must receive a RMA from the Service Department before sending your unit to Ashly.

2) Return the product to ASHLY AUDIO freight prepaid, with a written statement describing the defect and application that the product is used in. ASHLY AUDIO will examine the product and perform any necessary service, including replacement of defective parts, at no further cost to you.

3) Ship your product to:

ASHLY AUDIO

Service - RMA (insert RMA#)

847 Holt Road

Webster, NY 14580-9103

ASHLY AUDIO 847 Holt Road Webster, NY 14580-9103, USA
 Phone: (585) 872-0010 Fax: (585) 872-0739
 Toll Free (800) 828-6308 www.ashly.com

An **exertis** | **JAM** business

©2020 Ashly Audio. All rights reserved worldwide.

All features, specifications, and graphical representations are subject to change or improvement without notice.