



# AquaTouch™ 7

Control Tablet

## Operating Manual



## Important Safety Instructions • Consignes de sécurité à lire attentivement



1. Read these instructions.
2. Keep these instructions.
3. Heed all warnings.
4. Follow all instructions.
5. To reduce the risk of fire or electric shock, do not expose this apparatus to rain or moisture.
6. Do not use this apparatus near water.
7. Clean only with dry cloth.
8. Do not block any ventilation openings. Install in accordance with the manufacturer's instructions.
9. Do not install near any heat sources such as radiators, heat registers, stoves, or other apparatus.
10. Do not defeat the safety purpose of the polarized or grounding-type plug. A polarized plug has two blades with one wider than the other. A grounding type plug has two blades and a third grounding prong. The wide blade or the third prong are provided for your safety. If the provided plug does not fit into your outlet, consult an electrician for replacement of the obsolete outlet.
11. Protect the power cord from being walked on or pinched particularly at plugs,

The lightning flash with arrowhead symbol, within an equilateral triangle, is intended to alert the user to the presence of uninsulated "dangerous voltage" within the product's enclosure that may be of sufficient magnitude to constitute a risk of electric shock to persons. The exclamation point within an equilateral triangle is intended to alert the user to the presence of important operating and maintenance instructions in the literature accompanying the device.

convenience receptacles, and the point where they exit from the apparatus.

12. Only use attachments/ accessories specified by the manufacturer.
13. Use only with the cart, stand, tripod, bracket, or table specified by the manufacturer, or sold with the apparatus. When a cart is used, use caution when moving the cart/ apparatus combination to avoid injury from tip-over.
14. Unplug this apparatus during lightning storms or when unused for long periods of time.
15. Refer all servicing to qualified service personnel. Servicing is required when the apparatus has been damaged in any way, such as power-supply cord or plug is damaged, liquid has been spilled or objects have fallen into the apparatus, the apparatus has been exposed to rain or moisture, does not operate normally, or has been dropped.

Le symbole de la foudre dans un triangle équilatéral symbolisant la foudre est prévu pour sensibiliser l'utilisateur à la présence de tension de voltage non isolée à l'intérieur de l'appareil. Elle pourrait constituer un danger de risque de décharge électrique pour les utilisateurs. Le point d'exclamation dans le triangle équilatérale alerte l'utilisateur de la présence de consignes qu'il doit d'abord consulter avant d'utiliser l'appareil.

1. Lisez ces instructions.
2. Conservez ces instructions.
3. Observez les avertissements.
4. Suivez ces instructions.
5. Pour réduire le risque de feu ou la décharge électrique, ne pas exposer cet appareil pour pleuvoir ou l'humidité.
6. Ne pas utiliser l'appareil près de l'eau.
7. Le nettoyer à l'aide d'un tissu sec.
8. Ne pas bloquer les ouvertures de ventilation, installer selon les consignes du fabricant.
9. Eloigner des sources de chaleur tel: radiateurs, fourneaux ou autres appareils qui produisent de la chaleur.
10. Ne pas modifier ou amputer le système de la mise à terre. Une prise avec mise à terre comprend deux lames dont une plus large ainsi qu'une mise à terre: ne pas la couper ou la modifier. Si la prise murale

n'accepte pas la fiche, consulter un électricien pour qu'il remplace la prise désuète.

11. Protéger le cordon de secteur contre tous bris ou pincement qui pourraient l'endommager, soit à la fiche murale ou à l'appareil.
12. N'employer que les accessoires recommandés par le fabricant.
13. N'utiliser qu'avec les systèmes de fixation, chariots, trépied ou autres, approuvés par le fabricant ou vendus avec l'appareil.
14. Débrancher l'appareil lors des orages électriques ou si inutilisé pendant une longue période de temps.
15. Un entretien effectué par un centre de service accrédité est exigé si l'appareil a été endommagé de quelque façon: si il a été exposé à la pluie,, l'humidité ou s'il ne fonctionne pas normalement ou qu'il a été échappé.

## FCC Compliance

This device complies with part 15 of the FCC Rules. Operation is subject to the following two conditions:

- This device may not cause harmful interference
- This device must accept any interference received, including interference that may cause undesired operation

Note: This equipment has been tested and found to comply with the limits for a Class B digital device, pursuant to part 15 of the FCC Rules. These limits are designed to provide reasonable protection against harmful interference in both a commercial and residential installation. This equipment generates, uses and can radiate radio frequency energy and, if not installed and used in accordance with the instructions, may cause harmful interference to radio communications. However, there is no guarantee that interference will not occur in a particular installation. If this equipment does cause harmful interference to radio or television reception, which can be determined by turning the equipment off and on, the user is encouraged to try to correct the interference by one or more of the following measures:

- Reorient or relocate the receiving antenna.
- Increase the separation between the equipment and receiver.
- Connect the equipment into an outlet on a circuit different from that to which the receiver is connected.
- Consult the dealer or an experienced radio/TV technician for help.

## Unpacking

As a part of our system of quality control, every Ashly product is carefully inspected before leaving the factory to ensure flawless appearance.

After unpacking, please inspect for any physical damage. Save the shipping carton and all packing materials, as they were carefully designed to reduce to a minimum the possibility of transportation damage should the unit again require packing and shipping. In the event that damage has occurred, immediately notify your dealer so that a written claim to cover the damages can be initiated.

The right to any claim against a public carrier can be forfeited if the carrier is not notified promptly and if the shipping carton and packing materials are not available for inspection by the carrier. Save all packing materials until the claim has been settled.

## About Ashly

Ashly Audio was founded in 1974 by a group of recording engineers, concert sound professionals, and electronics designers. The first products were elaborate custom consoles for friends and associates, but business quickly spread to new clients and the business grew.

The philosophy we established from the very beginning holds true today: to offer only the highest quality audio tools at an affordable cost to the professional user – ensuring reliability and long life. Years later, Ashly remains committed to these principles.

Ashly's exclusive Five-ear, Worry-Free Warranty remains one of the most generous policies available on any commercial-grade product. The warranty covers every product with the Ashly brand name, and is offered at no extra cost to you.

Please read this entire manual to fully understand the features and capabilities of this product.

## 1 Introduction

Thank you for your purchase of the AquaTouch7™ remote control tablet. The AquaTouch7 is used for Ashly products equipped with AquaControl™ software. No other application is needed since AquaControl software is served directly from the connected device under control.

The AquaTouch7 tablet is designed primarily for use as a secure, limited access remote control device for AquaControl products, configured and deployed by the AquaControl system admin for remote operator use. While it is possible to use the tablet for complete admin level access to an AquaControl device, due to its smaller screen size it is best suited for accessing the remote control screens served up from the target device.

## 2 Installation

### 2.1 Wiring

The AquaTouch7 requires Power-Over Ethernet (PoE) and is compliant with IEEE 802.3af. Connect the tablet to a network router that provides PoE, or use a PoE injector in series with the AquaTouch7 Ethernet connection. WiFi network communication is not available.

### 2.2 Network Connection

- AquaTouch7 must be connected to a DHCP router.
- AquaTouch7 must be installed on the same LAN as the target AquaControl device, i.e., connected to the same router..

- AquaTouch7 is factory configured for Automatic (DHCP) IP assignment, so it will automatically be configured when connected to the network router.

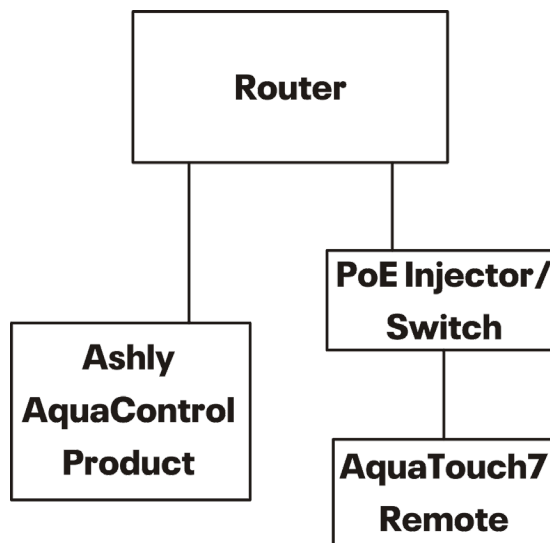

### 2.3 Mechanical

The AquaTouch7 includes a mounting bracket for fastening the tablet to a US or EU electrical wall box. Typical wall box mounting height is 59" (150cm). Make sure the wall box is mounted level and flush to the wall surface.

1) Install the mounting bracket to the wall box using the included screws, making sure the two small tabs sticking out from the mounting plate are facing away from the wall.

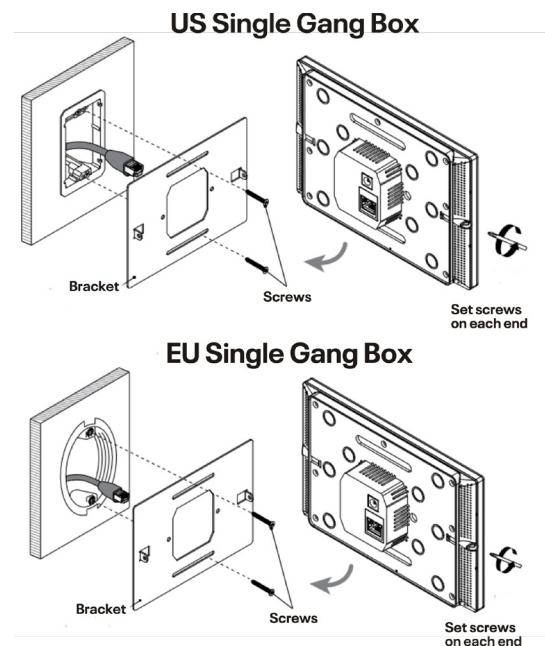

2) There are two set screws at either end of the tablet. Using the screwdriver provided, screw these all the way in, then unscrew 1 full turn to allow a gap for the mounting bracket tabs to fit into. These screws secure the tablet to the mounting plate tabs using the slots next to each set screw.

3) Connect the Ethernet cable that has been run through the wall box to the tablet LAN/PoE Jack. Make sure that the tablet powers up before attaching it to the wall.

4) Using the two small slots on the back of the tablet, fit the tablet onto the mounting plate, then tighten both set screws until the tablet is secured to the mounting plate.

### 3 AquaControl Connection

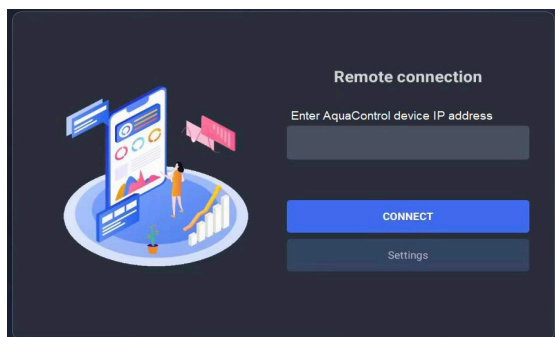

After wiring to the network and booting the AquaTouch7, the above Remote Connection screen appears.

Connect the tablet to the target AquaControl device by entering the target device's physical IP address (see sec. 4), then press the "CONNECT" button.

*To return to this screen from any AquaControl screen, press and hold your finger in the very upper left corner of the screen for at least five seconds or until the Remote Connection screen appears.*

**Using tablet as Operator:** If you are connecting to the target AquaControl device for the first time and have been given an Operator role username, the tablet will prompt for the target AquaControl device login credentials that were assigned to you by the AquaControl admin. The admin will have created your account username, role, and password, and if that role is set as an Operator, granted specific permissions for that role.

If the target AquaControl device and AquaTouch7 have previously been connected using an Operator login, the tablet remains connected using that role.

In the event of a power outage, the AquaTouch7 will automatically log back into AquaControl if the "Remember me" box was checked at the last login. Note: it takes up to a minute for the AquaTouch7 to commit the Login session security token to flash memory, so if the power is removed less than a minute after Login then you may need to Login again the next time power is applied.

**Using tablet as Admin:** While it is possible to log in to the target AquaControl device and use it as an Admin, the tablet's limited screen size makes it challenging due to its small feature size.

*Note: Usernames and passwords are case sensitive.*

### 4 AquaControl Device IP Address

- **To find the IP address** of the target AquaControl device, log in to its [Settings -> Network Settings] screen as shown below. Enter this IP address in the AquaTouch7 Remote Connection screen.

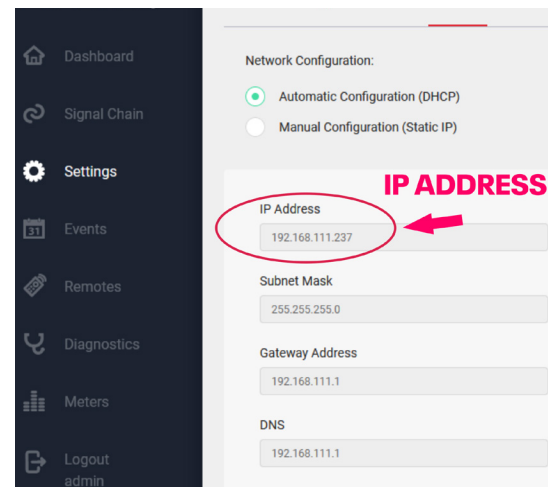

- The DHCP server (router), may arbitrarily re-assign a new IP address to the target AquaControl device if the IP lease expires or the device gets re-booted.

To avoid losing the network connection between the AquaTouch7 and the targeted AquaControl device, the network admin should set an IP reservation for the AquaControl target device in the network DHCP router's administration settings.

## 5 AquaTouch7 Settings

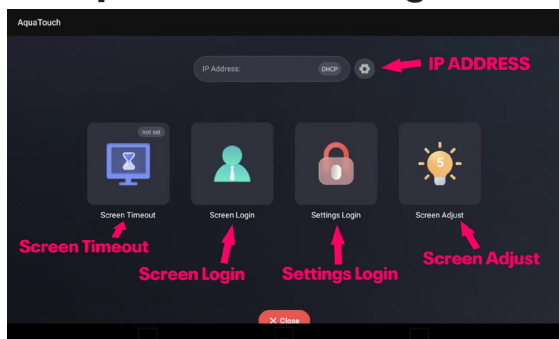

In the Remote Connection home screen, press the "Settings" button to access the tablet features as shown above:

**IP Address:** This line displays the tablet's IP address, which should be set to DHCP. Connect the AquaTouch7 to a DHCP router ([see sec. 2.2](#)).

**Screen Timeout:** This sets the time it takes for the screen to go dark when there is no user activity. Touch the screen to turn it back on.

**Screen Login:** This offers an optional four-digit passcode requirement to unlock the screen after a screen timeout occurs.

**Settings Login:** This offers an optional four-digit passcode requirement to return to the Remote Connection and Settings page from the established AquaControl connection.

**Screen Adjust:** This adjusts the overall screen brightness. It also enables/disables the ability of the tablet screen to auto-rotate based on its position, however the tablet is best used in the horizontal orientation.

## 6 Specifications

<b>Screen</b>	7", 800 x 1280 TFT touchscreen
<b>Power</b>	PoE, 802.3af
<b>Compatibility</b>	Ashly AquaControl devices
<b>Unit dimensions</b>	7" x 4.5" x 1.35" (178mm x 114mm x 34.3mm)
<b>Unit weight</b>	0.75lbs (0.34kg)
<b>Shipping box dimensions</b>	8.75" x 6" x 2.6" (222mm x 152mm x 66mm)
<b>Shipping weight</b>	1.6lbs (0.73kg)
<b>Environmental</b>	40°-120°F (4°-49°C) noncondensing
<b>Safety/ Compliance</b>	CE, FCC Class B, RoHS, UL, CSA

## LIMITED WARRANTY (USA ONLY)

(Other countries please contact your respective distributor or dealer.)

For units purchased in the USA, warranty service for this unit shall be provided by ASHLY AUDIO in accordance with the following warranty statement.

ASHLY AUDIO, an **exertis|JAM** business, warrants to the owner of this product that it will be free from defects in workmanship and materials for a period of FIVE years from the original-date-of-purchase.

ASHLY AUDIO will without charge, repair or replace at its discretion, any defective product or component parts upon prepaid delivery of the product to the ASHLY AUDIO factory service department, accompanied with a proof of original-date-of-purchase in the form of a valid sales receipt. This warranty gives you specific legal rights, and you may also have other rights, which vary from state to state.

**EXCLUSIONS:** This warranty does not apply in the event of misuse, neglect, or as a result of unauthorized alterations or repairs made to the product. This warranty is void if the serial number is altered, defaced, or removed. ASHLY AUDIO reserves the right to make changes in design, or make additions to, or improvements upon, this product without any obligation to install the same on products previously manufactured.

Any implied warranties, which may arise under the operation of state law, shall be effective only for FIVE years from the original-date-of-purchase of the product. ASHLY AUDIO shall be obligated to only correct defects in the product itself. ASHLY AUDIO is not liable for any damage or injury, which may result from, or be incidental to, or a consequence of, such defects. Some states do not allow limitations on how long an implied warranty lasts, or the exclusion, or limitation of incidental or consequential damages, so the above limitations or exclusions may not apply to you.

## OBTAINING WARRANTY SERVICE:

For warranty service in the United States, please follow this procedure:

1) Contact the Ashly Service Department at 800-705-2102 or <https://ashly.com/technical-support/> to receive an RMA number. You must receive a RMA from the Service Department before sending your unit to Ashly.

2) Return the product to ASHLY AUDIO freight prepaid, with a written statement describing the defect and application that the product is used in. ASHLY AUDIO will examine the product and perform any necessary service, including replacement of defective parts, at no further cost to you.

3) Ship your product to:

ASHLY AUDIO

Service - RMA (insert RMA#)

847 Holt Road

Webster, NY 14580-9103

ASHLY AUDIO 847 Holt Road Webster, NY 14580-9103, USA  
Phone: (585) 872-0010 Fax: (585) 872-0739  
Toll Free (800) 828-6308 [www.ashly.com](http://www.ashly.com)

An **exertis** | **JAM** business

©2024 Ashly Audio. All rights reserved worldwide.

All features, specifications, and graphical representations are subject to change or improvement without notice.